

# CAYMAN

## Primary Social Studies



WORKBOOK

2

**Cayman Islands**  
**Primary Social Studies**

WORKBOOK 2



Macmillan Education  
Between Towns Road, Oxford OX4 3PP  
A division of Macmillan Publishers Limited  
Companies and representatives throughout the world

ISBN : 978-0-333-98805-3

Text © Education Department, Cayman Islands 2003  
Design and illustration © Macmillan Publishers Limited 2003

First published 2003

All rights reserved; no part of this publication may be reproduced, stored in a retrieval system, transmitted in any form or by any means, electronic, mechanical, photocopying, recording, or otherwise, without the prior written permission of the publishers.

Typeset by J&D Glover Ltd  
Illustrated by David Woodroffe  
Cover design by Gary Fielder, AC Design  
Cover photograph by Andrew Guthrie

The authors and publishers would like to thank the following for permission to reproduce the following photographic material:  
Corbis p40 (tl, tr, bc, br) ©Bettmann, (tc) ©David Turnley;  
Mary Evans Picture Library p40 (bl)

The publishers have made every effort to trace all the copyright holders, but if they have inadvertently overlooked any, they will be pleased to make the necessary arrangements at the first opportunity.

Printed and bound in Malaysia

2010 2009 2008 2007  
13 12 11 10 9 8 7 6 5 4 3

## **Contents**

Theme 1	Our Community	4
Theme 2	Our Changing Community	20
Theme 3	People Who Help Us	32
Theme 4	Heritage, Symbols and Songs	37
Cut-out page		47

# 1

## Our Community



Our community is where we live work and play.

1 What is the name of your community?

The name of my community is \_\_\_\_\_

2 Take a walk around your community. List some of the things you see.

---

---

---

3 Draw a picture of your community. Label the places you draw.

Circle in red the places where people work.

Circle in blue the places where people play.

# Directions

We use a compass to tell the directions of places.

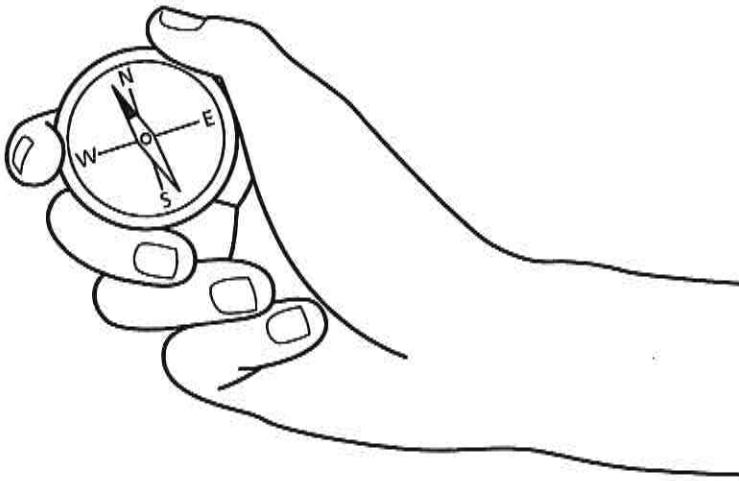

A compass rose tells us the direction of places on a map or picture.

Label the directions correctly, using words from the box below.

South    East    West

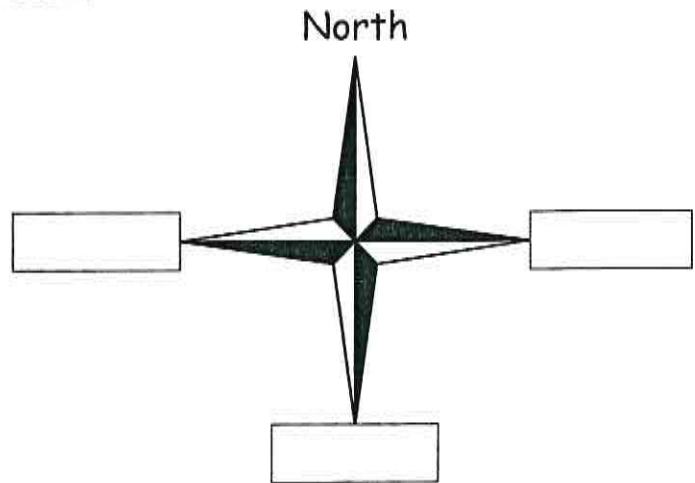

This compass rose shows eight directions. Some are labelled. Can you label the others correctly?

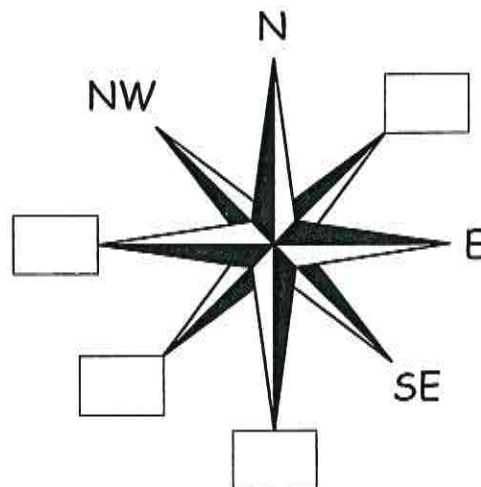

Tom lives in a small town. He is cycling to his Grandmother's house. Look at the picture and answer the questions on page 7.

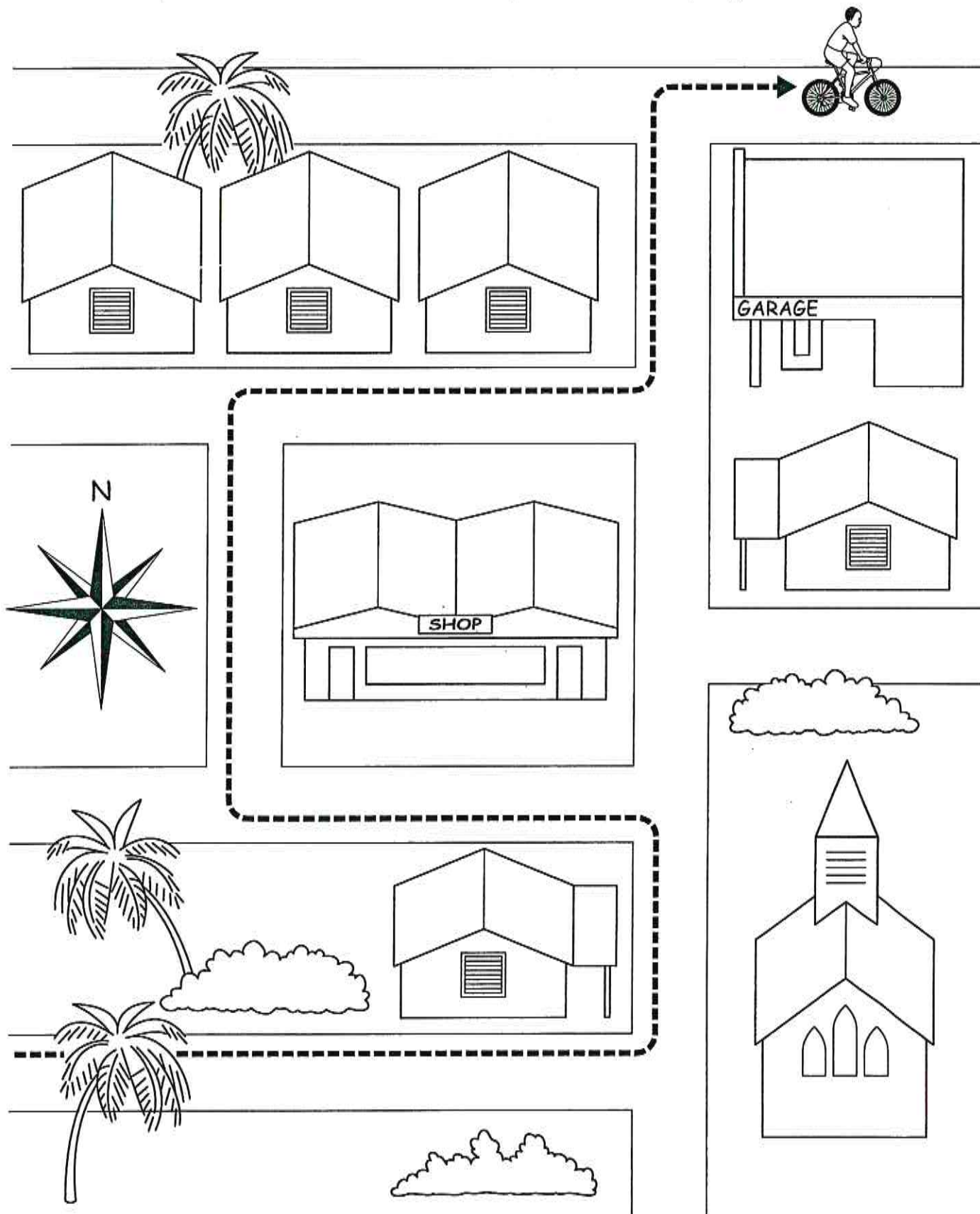

In which direction is Tom cycling now?

\_\_\_\_\_

Which direction is he from the church?

\_\_\_\_\_

How many times has he turned left?

\_\_\_\_\_

Which direction is the garage from the shop?

\_\_\_\_\_

Which direction did Tom come from?

\_\_\_\_\_

In pairs, make up and answer questions about directions in the picture.

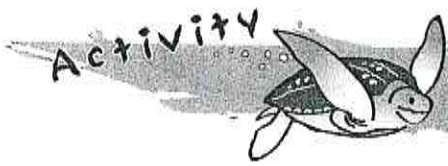

Write the story of Tom's journey. Use 'left' and 'right' and compass directions to explain his route through town.

Lined writing area for the student's response.

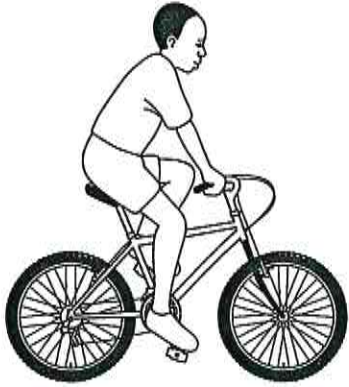



# Our districts

This map shows the districts of the Cayman Islands.

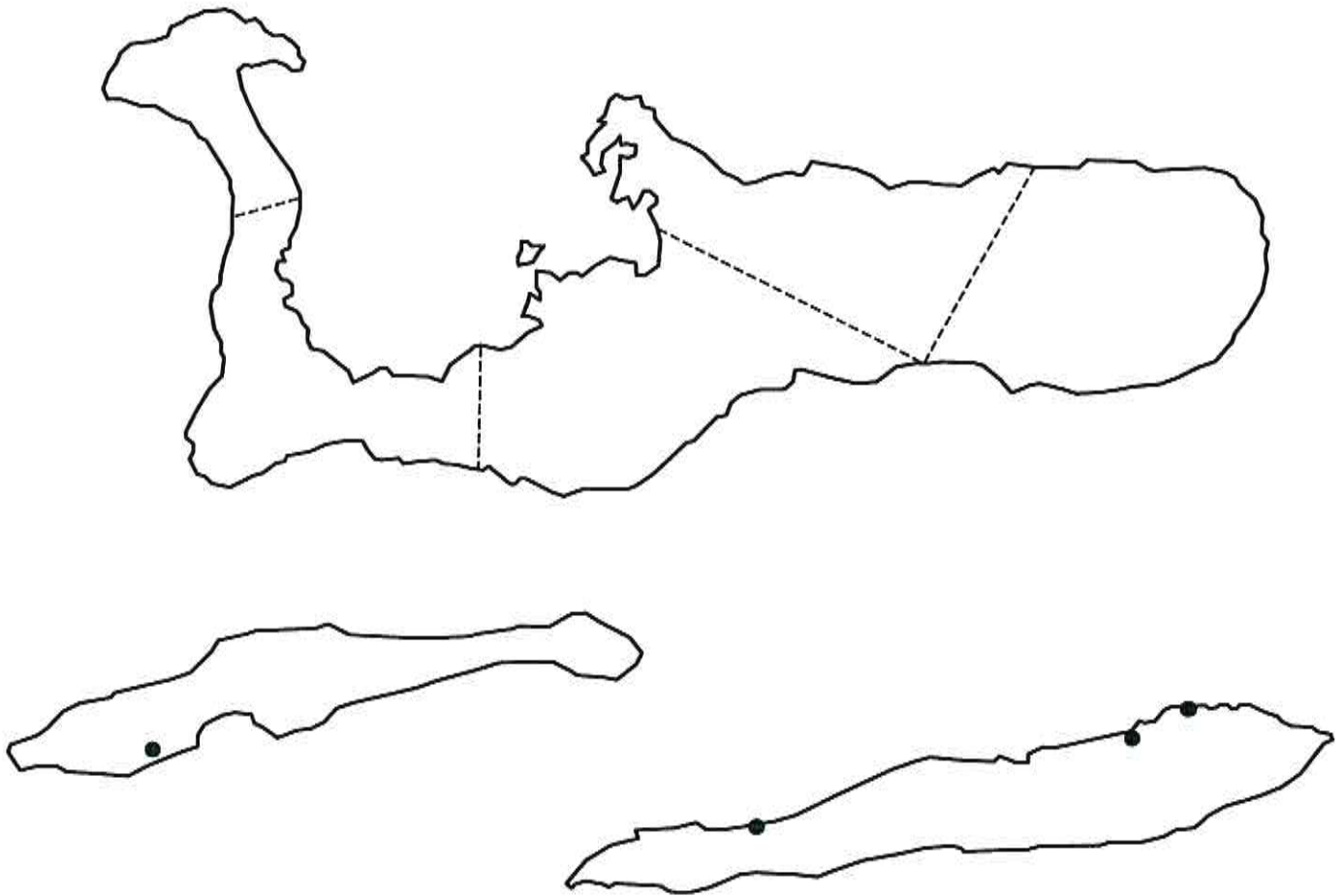

Write the district names in the right places on the map.  
Mark and label your own community on the map.

Answer these questions.

1 Little Cayman and Cayman Brac make up how many districts?

\_\_\_\_\_

2 Name one community on Grand Cayman.

\_\_\_\_\_

3 Name one community on Little Cayman.

\_\_\_\_\_

4 Name one community on Cayman Brac.

\_\_\_\_\_

5 Which district is furthest to the east?

\_\_\_\_\_

6 Which district do you live in?

\_\_\_\_\_

# What our community looks like

This picture shows a community. Colour the natural features on this picture. Do not colour the man-made features.

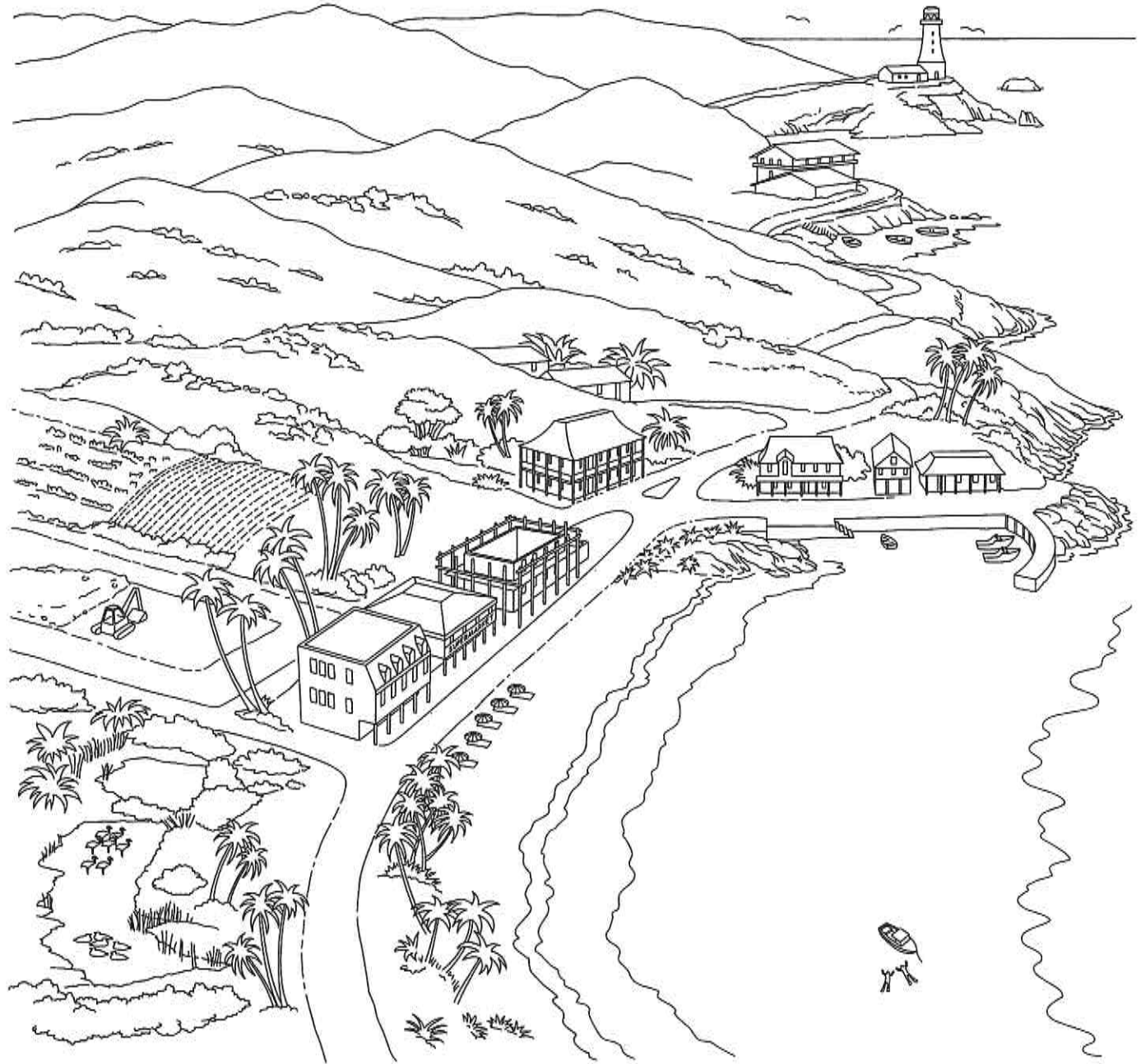

Label the natural and man-made features using words from the box below.

hill beach pond tree bush road house field shop

# My community

Tick those sentences that are true about your community.

- 1 It is near the sea.
- 2 It is on an island.
- 3 It is in a sheltered place.
- 4 It is in the west of Grand Cayman.
- 5 It is on Cayman Brac.
- 6 There are shops in my community.
- 7 There is good farmland in my community.
- 8 There are hills.
- 9 It is on Little Cayman.

Write some more sentences about your community.

---

---

---

---

---

---

---

---



Find out how old your community is.

## Families in the community

Draw a picture of your family. Label the people in the picture.

Look at the pictures of families on page 8 of your textbook. Talk about the things that are the same as and the things that are different from your family.

Write three sentences about your family below.

---

---

---

---

# Pictures and maps

A map is a picture of a place drawn from above. These objects have been drawn from above.

Draw lines to match each of these maps to the correct object.

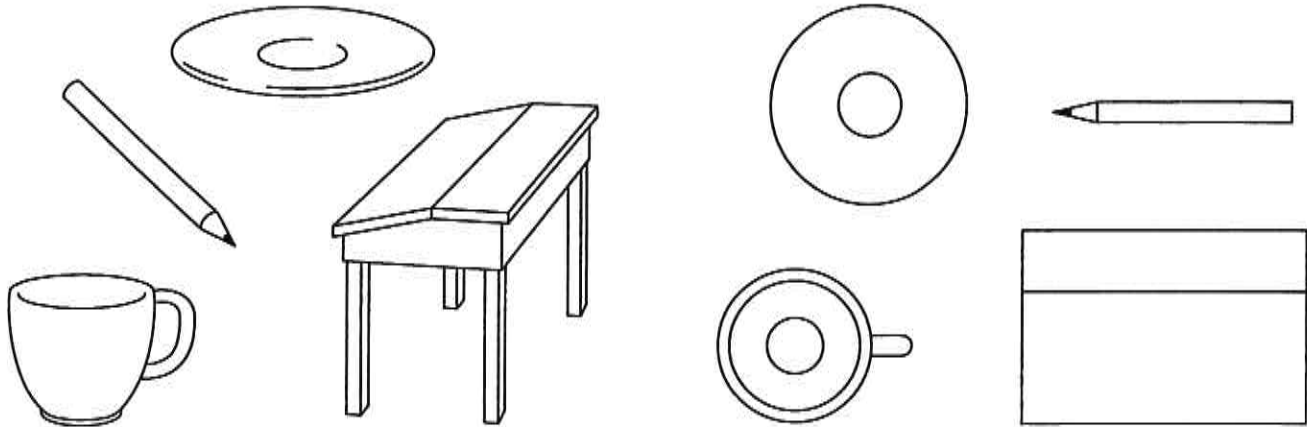

Draw pictures to show the side views of the things shown in the maps below.

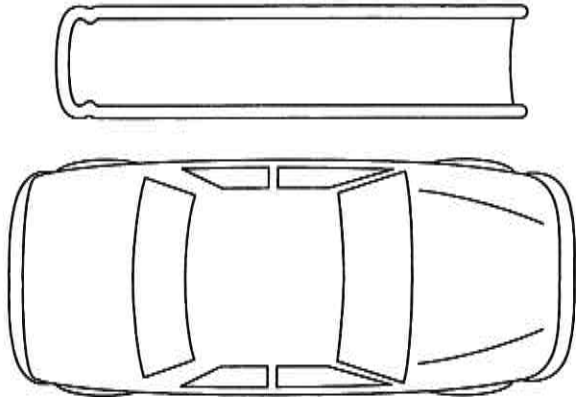

Now draw maps of these objects.

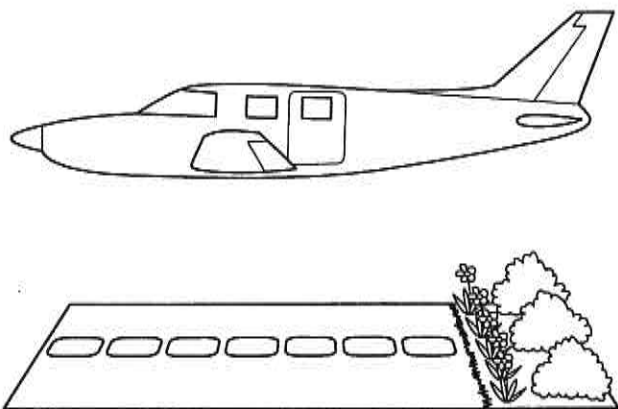

Look at the map of Kendra's community on page 11 of your textbook. North is at the top of the map.

Answer these questions.

1 What direction is Kendra's school from the public beach?

---

2 What direction is the gas station from the church?

---

3 What direction does Kendra walk in to get to school?

---

4 What direction does Kendra walk in when she goes home from the public beach?

---

5 What direction is Kendra's house from the gas station?

---

Write some sentences about Kendra's route to school. The first one has been done for you.

*Kendra turns left out of her house and walks up Shamrock Road.*

---

---

---

---

---

---

---

---

Draw a map of the area near to your home.

Label your map. Add a compass rose to show the directions.

Write some sentences about your journey to school. Use some of the words in the box below.

---

---

---

---

turn right left straight north south east west

## Places people visit

Look at the map of Bodden Town on pages 12 and 13 of your textbook.  
List five places that people visit.

---

---

---

With a friend, practise giving directions from Kendra's house to each of these places.

List some places people visit in your community.

---

---

---

---

Draw a picture of one place you have visited.

Name the place you have drawn. \_\_\_\_\_

Is it natural or man-made? \_\_\_\_\_

Why is it important? \_\_\_\_\_



# Sports

Draw lines to match the sports equipment to the right sport.

Football

Cricket

Windsurfing

Diving

Tennis

Golf

Basketball

Fishing

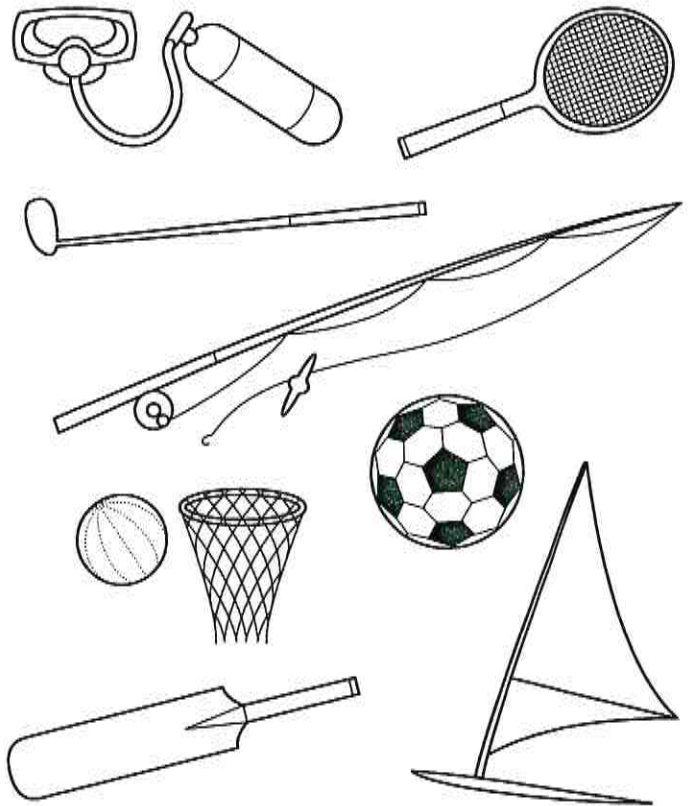

What is your favourite sport? \_\_\_\_\_

Name three sports played at your school.

---

---

---

On a sheet of paper, draw a picture of yourself playing a sport. Write the name of the sport below your picture.

Activity

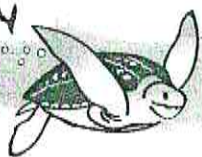

Collect pictures of different sports from old magazines and brochures. Use them to make a poster about sport and put it on the bulletin board.

# Water

Write a sentence for each picture. Explain how water is being used.

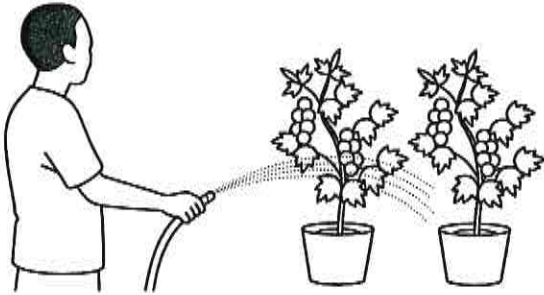

On a sheet of paper, draw pictures to show where we get water from and where we store water.

# How much water do we use?

This is how much water we use for different activities:



Bath:  
25 gallons



Shower:  
6 gallons



Toilet flush:  
2 gallons



Cooking and washing for one  
person for a day: 10 gallons

Keep a water record. For one day record how much water you use.  
Copy this table. You can add some other uses to it.  
Make a tally mark each time you use water.

	Number of times	Total amount of water
Drink		
Wash hands		
Toilet flush		
Bath		
Shower		

Find out how much water you use for each drink. \_\_\_\_\_

Find out how much water you use when you wash your hands. \_\_\_\_\_

Work out the amount of water you used in a day for each activity (see the pictures above). Write this in your table. Now add up the total amount of water you used. Total water used in one day: \_\_\_\_\_

How much water would you use in a week? \_\_\_\_\_

Talk about your findings in a group. Do you use more or less water than other children in your class?

# Things we use

Look at page 19 in your textbook. List the things that are imported.

---

---

---

Look at the labels on things you use. Read what countries they come from. Copy the table below and write in some more. One has been done for you.

Things we use	Country they come from
Medicines	United States of America (USA)



Mark on this map where some things come from. Two have been done for you.



Collect labels showing which countries things have come from. Find the countries on a map of the world.

# 2

## Our Changing Community

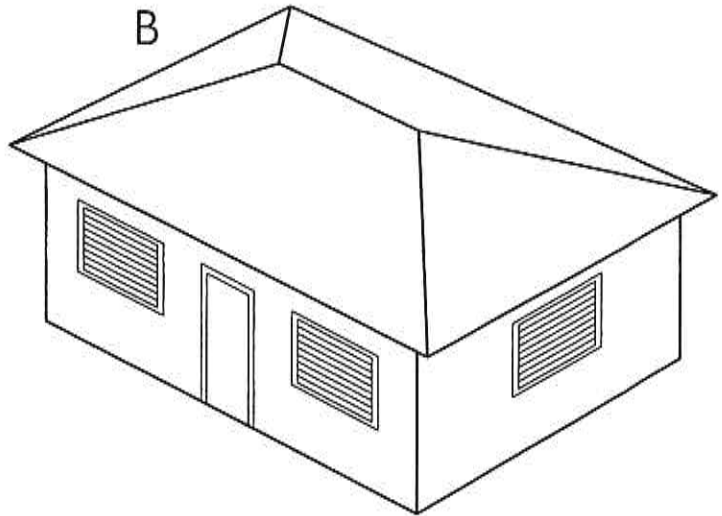
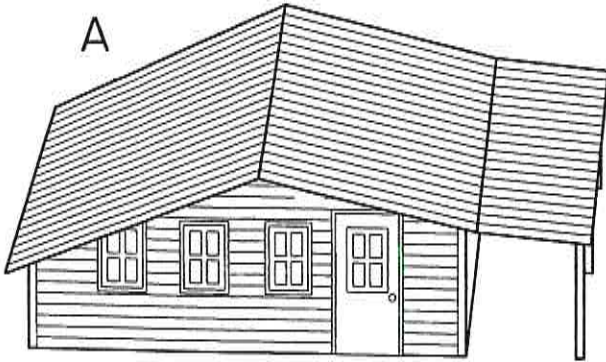

Look at these pictures.

Which house is old and which is modern? \_\_\_\_\_

Write down three differences between the houses.

---

---

---

Write down three ways in which the houses are the same.

---

---

---

Activity

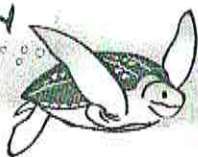

Find out six things that are different now from in the past.

Make a chart or poster to show the differences and display it in your classroom.

# Road safety

What must you do before you cross the road? Fill in the blanks.

You must s\_\_\_\_\_, \_\_\_\_\_, l\_\_\_\_\_ and \_\_\_\_\_.

Match these road signs to their meanings.

Stop

Children crossing

Pedestrian crossing

Give way

Prepare to stop

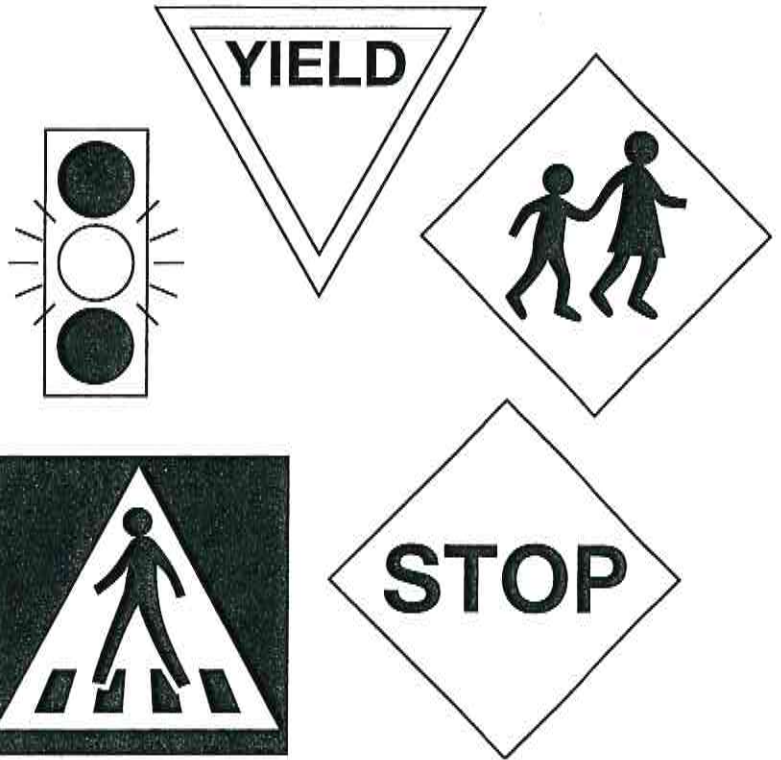

Draw some other road signs below and say what they mean.

## Our important buildings

Read pages 24 and 25 of the textbook and look at the pictures there. Answer these questions.

What is the name of our capital? \_\_\_\_\_

Where are most of our government buildings? \_\_\_\_\_

Name one new building in George Town. \_\_\_\_\_

Name one old building in Cayman Brac. \_\_\_\_\_

Is the Legislative Assembly old or new? \_\_\_\_\_

What happens at the Library? \_\_\_\_\_

Draw pictures of two important buildings in your community. Label each with its name.

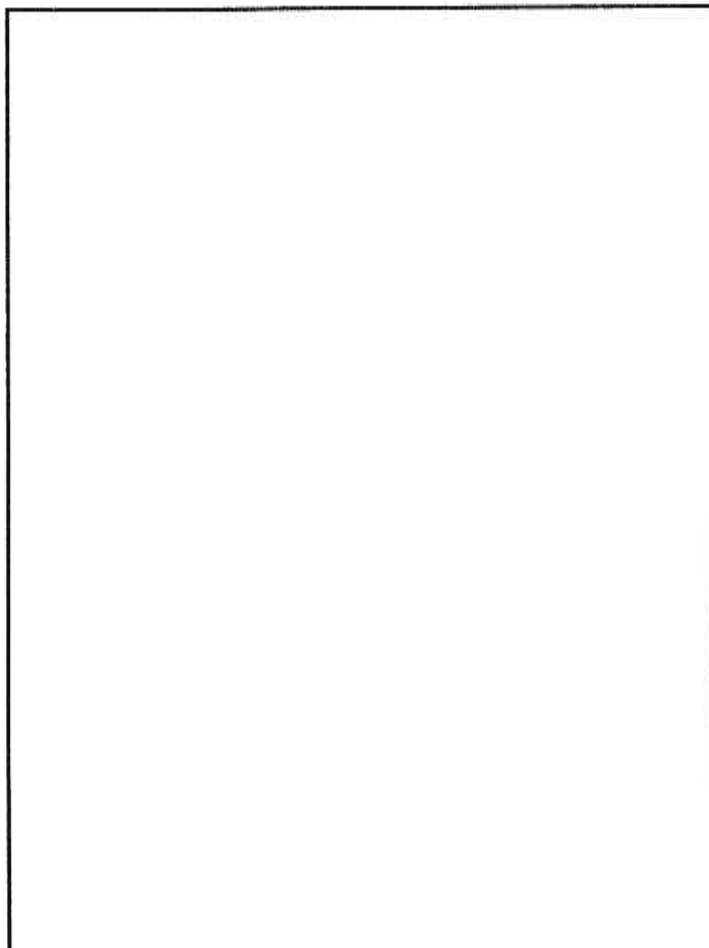
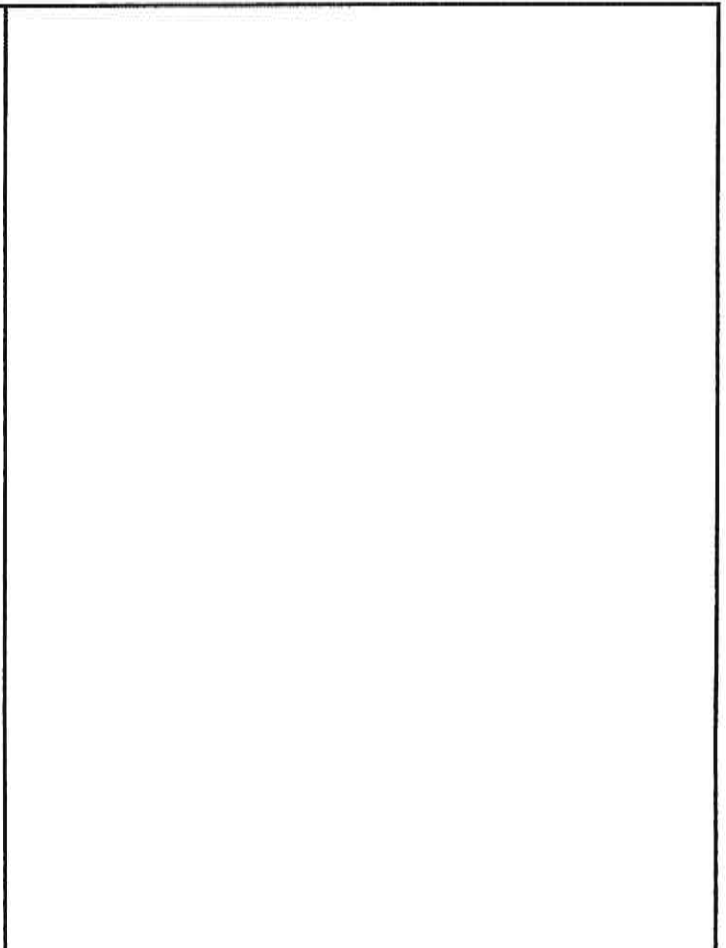
 _____	 _____
---	--

## Our churches

Name one church in your community.

---

List three ways that people worship in church.

---

---

---

Visit a church. Draw a picture of the outside of the church or of some of the things inside. Label your picture.

In groups talk about why the church is important in your community. Share your answers with other groups.

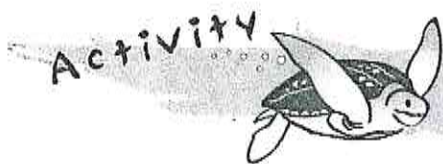

Collect pictures of different churches. Label them and paste them in a scrapbook.



## Our schools

What is the name of your school?

---

Write down four things you learn at school.

---

---

---

---

Draw a map of your classroom. Mark a cross to show where you sit. Put a 'T' to show the teacher's desk. Label the door, the chalkboard and the windows.

# School rules

Look at the School Rules on page 29 of your textbook. Talk about these School Rules with a friend. Make sure you know what each one means.

Are they the same as your school rules? \_\_\_\_\_

Does your school have any other rules? \_\_\_\_\_

Choose one rule. Write a story about someone who broke the rule and what happened.

---

---

---

---

---

---

---

---

---

---

---

---

---

---

---

---

---

---

---

---

---

---

---

---

---

---

---

---

---

---



You could type your story on the computer and print it out for a friend to read.

# Our museums

Look at the pictures below. They show things you can see at the museums.

Can you say what these things are?  
Write a sentence about each one.

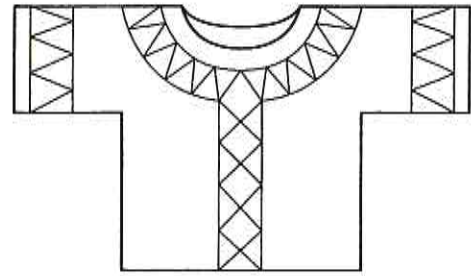
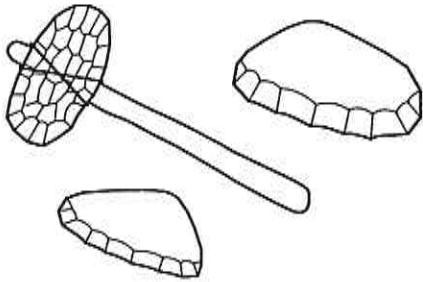

---

---

---

---

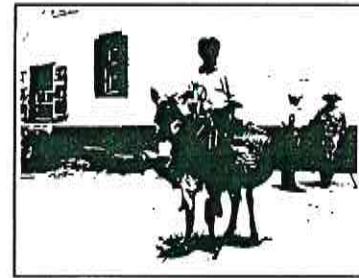
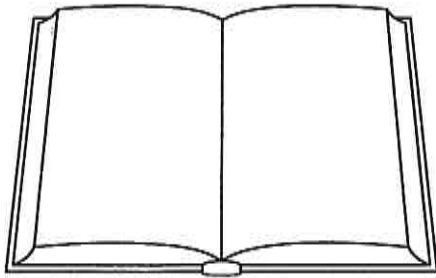

---

---

---

---

Give one reason why we visit museums.

---

Write some sentences saying why things in museums are important to us.

---

---

---

# Our plants

Look carefully at this diagram of a tree. It shows some of the things that we use plants for. Fill in the missing words and letters.

Trees provide homes for animals such as b\_\_\_\_\_ and insects.

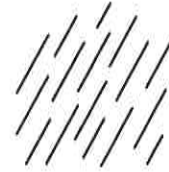

Trees help to bring r\_\_\_\_\_.

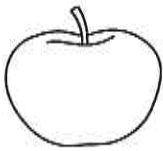

Some trees have f\_\_\_\_\_ that we can eat.

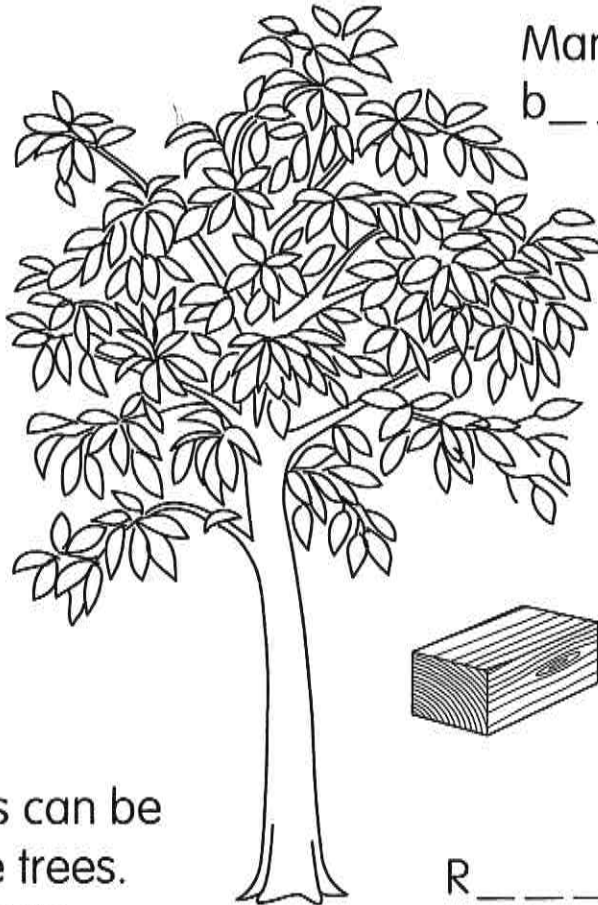

Many trees have b\_\_\_\_\_ t\_\_\_\_\_ful flowers.

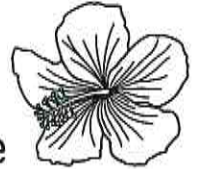

Tree canopies give us s\_\_\_\_\_ and shelter.

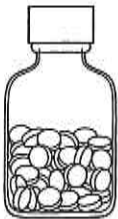

Med\_\_\_\_\_s can be made from some trees. For example, aspirin comes from willow.

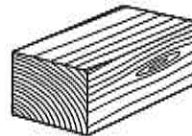

W\_\_\_\_\_ is used to make furniture and buildings.

R\_\_\_\_\_ stop the soil from being washed away.

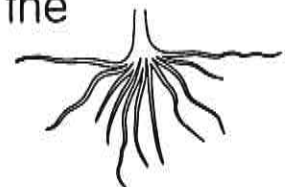

Choose one tree near your home or school. Find out more about your tree.

What type of tree is it?

Draw a picture of your tree on a sheet of paper.

# Wordsearch

There are ten plants in the wordsearch. How many can you find?

Circle the food plants with red pencil.

Circle the medicine plants with blue pencil.

B	A	N	A	N	A	C	X	M	K	Y	U
A	Z	O	N	M	P	O	I	A	J	H	P
S	K	L	M	D	F	C	E	N	H	W	E
O	Z	M	A	N	G	O	E	C	B	D	R
U	E	D	V	I	D	N	I	H	N	C	I
R	A	L	O	E	G	U	H	I	O	E	W
S	O	D	C	T	H	T	E	N	T	R	I
O	H	R	A	E	E	B	E	E	A	A	N
P	R	S	D	C	I	X	P	E	Q	S	K
W	A	C	O	B	D	Q	R	L	S	E	L
C	O	W	I	T	C	H	V	I	N	E	E
N	I	W	Y	T	P	A	C	H	T	A	M

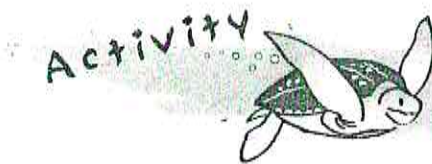

Collect leaves and seeds and stick them on a piece of paper to make a picture.

Collect pictures of plants. Use them to make a poster. Cut out your pictures and stick them on a large sheet of card with labels. Give the name of each plant and what it is used for.



Ask older people to tell you about other plants that can be used.

# Our weather

Fill in this weather chart for the week. Choose words from the box below to describe the weather. Then draw a picture for each day.

Monday		
Tuesday		
Wednesday		
Thursday		
Friday		
Saturday		
Sunday		

rainy   dry   windy   calm   cloudy   sunny   hot   cold

# The weather today

Use your senses to observe the weather today.

1 How windy is it?

(a) What direction is the wind coming from? \_\_\_\_\_  
(Hold up a piece of ribbon or strip of paper and watch which way it blows.)

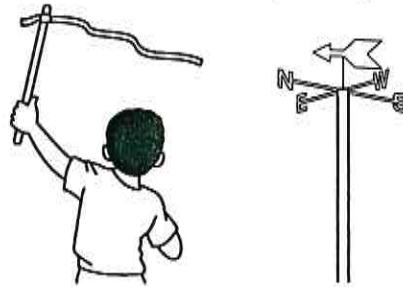

(b) How strong is the wind?  
Are leaves or branches moving on the trees? \_\_\_\_\_  
Is litter being blown along? \_\_\_\_\_  
Is clothing blowing on the clothes line? \_\_\_\_\_

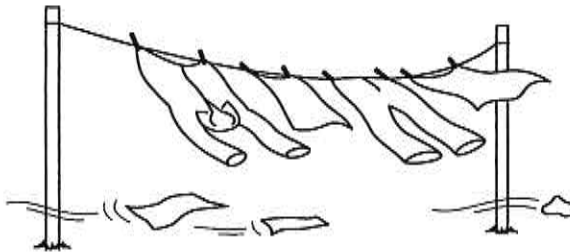

2 How hot or cold does it feel? \_\_\_\_\_

What clothes are people wearing? \_\_\_\_\_

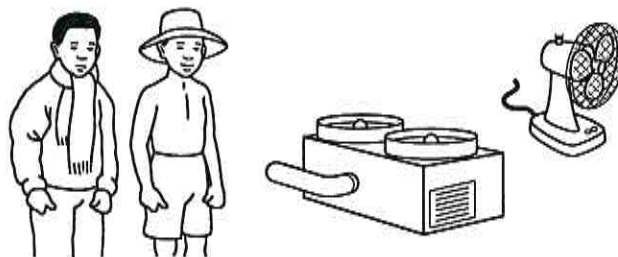

3 Is it sunny? \_\_\_\_\_

Is the sun shining? \_\_\_\_\_

Do you need sunglasses? \_\_\_\_\_



4 How cloudy is it?

Look at the sky. Are there any clouds? \_\_\_\_\_

How much of the sky do they cover? \_\_\_\_\_

Are the clouds high or low? \_\_\_\_\_

Are they white or dark? \_\_\_\_\_

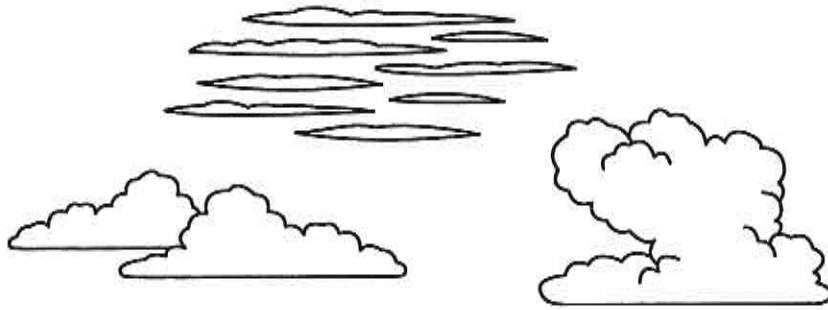

5 Is it raining? \_\_\_\_\_

How heavy is the rain? \_\_\_\_\_

How long does the rain last? \_\_\_\_\_



Draw a picture to show the weather today.



On a sheet of paper, draw a picture to show what you would see from inside a window looking out during a thunderstorm.



# 3

## People Who Help Us



Match, stick and colour.

See page 47. Cut out the words and pictures and stick them in the correct places.

Worker

Job

Clothes or tools

Puts out fires

Cleans our streets

Looks after sick people

Looks after our teeth

Teaches children at school

Grows our food

Keeps law and order

Choose one community worker.  
Draw a picture of him or her.

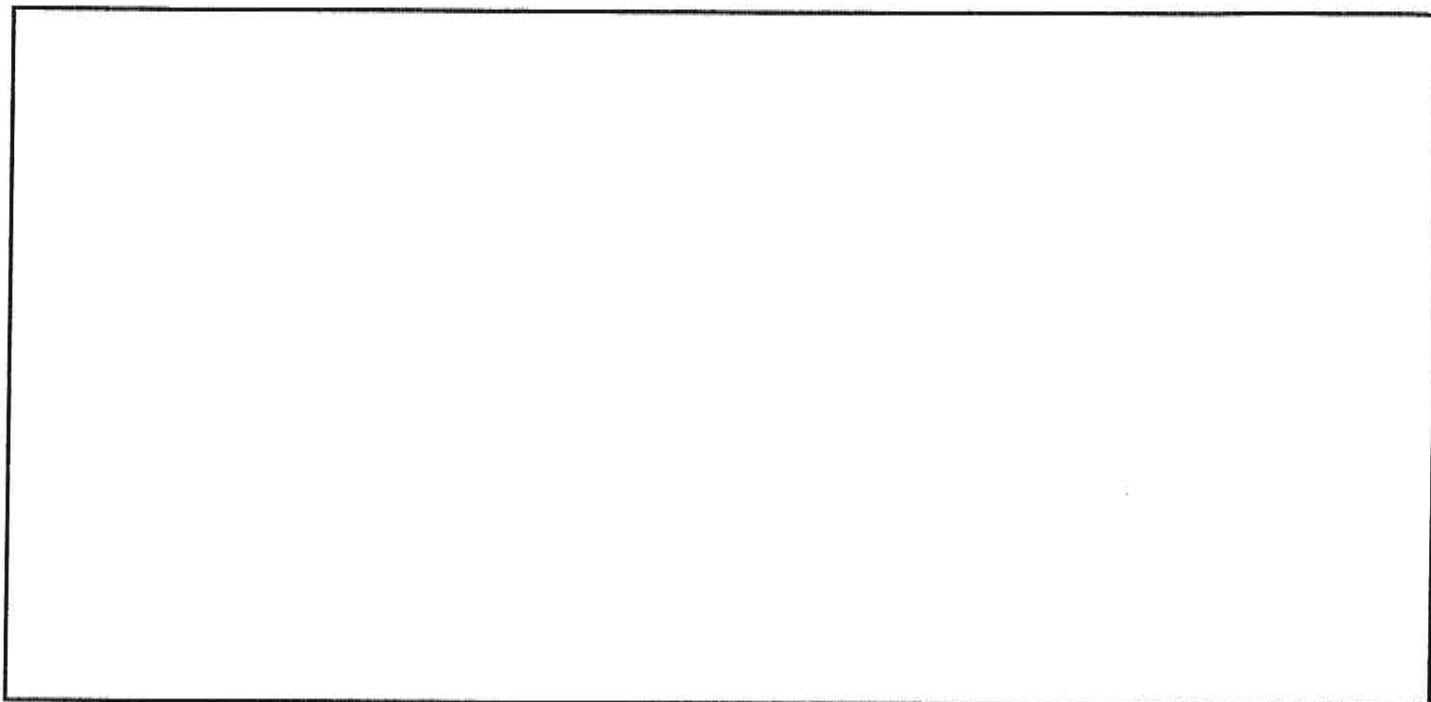

Draw the things this person would use for their job.

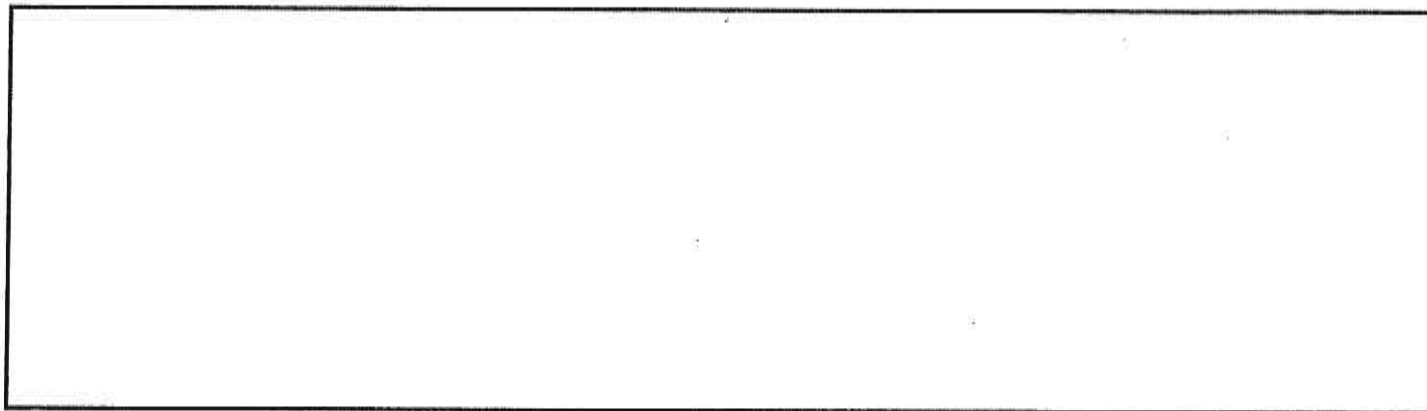

Where does this person work? \_\_\_\_\_

Write some sentences about the work that they do.

---

---

---

---

## Helping each other

1 Write down two ways in which your family help you.

---

---

2 Write down two ways in which you help other people in your family.

---

---

3 How do your friends help you?

---

---

4 Write down two ways you could help a friend.

---

---



Find out more about one special group, such as Scouts, Lions or Red Cross. What do they do?

---

---

Write down two or three words that are important for being polite.

---

With a friend practise being polite to:

- (a) older people, such as grandparents.
- (b) tourists.

# Keeping our community clean

This picture shows a dirty house.

Mark an X on all the things that need to be cleaned.

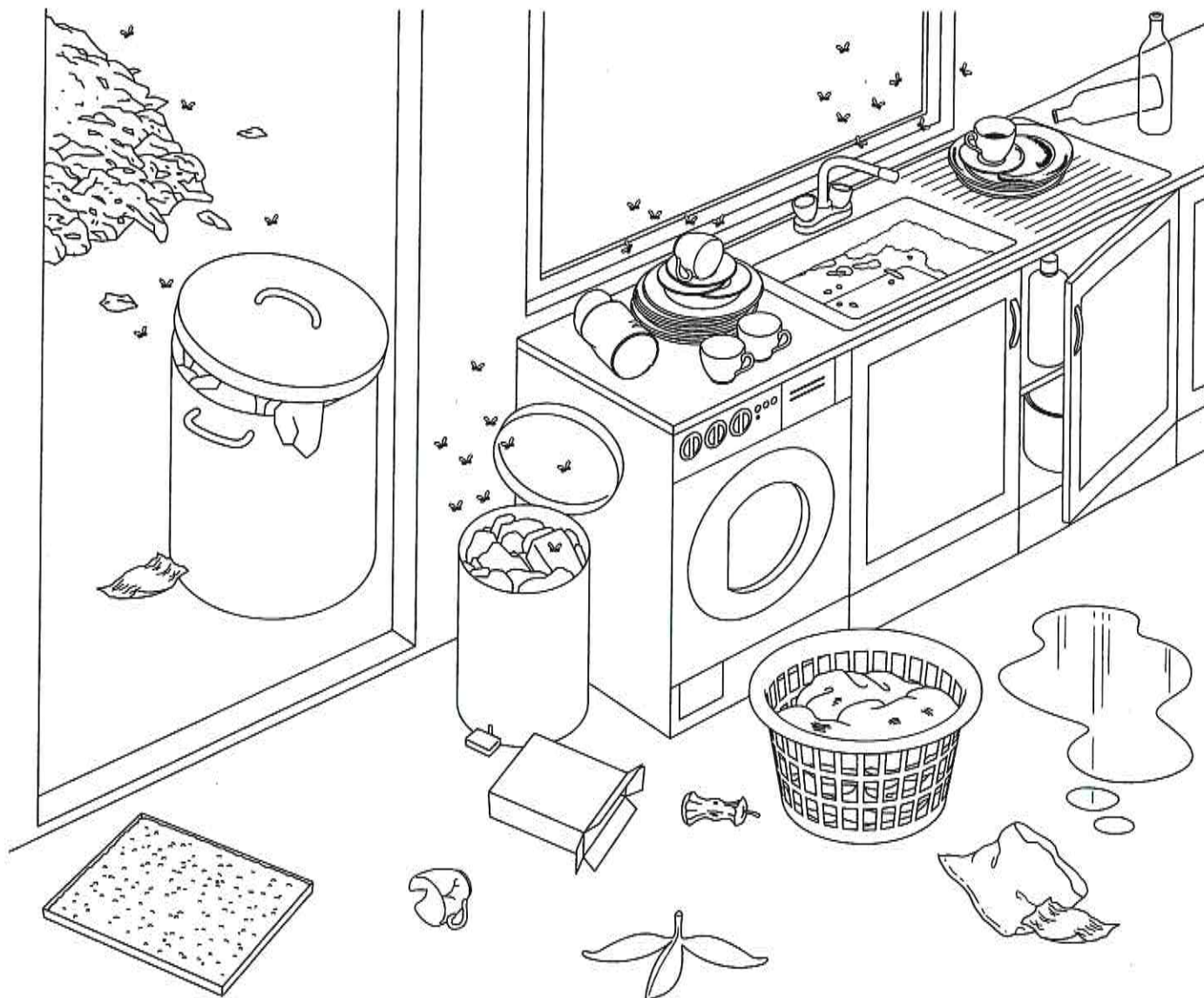

Write three reasons why cleanliness is important.

---

---

---

---

---

# Reuse, recycle or throw away?

It is best to reuse things or mend them if they are broken. If you can't reuse things, then recycle them. Only throw things away if you can't recycle them or they are dangerous.

Draw lines to show where to put the things.



Grass cuttings



Kitchen waste



Tin cans



Glass bottles

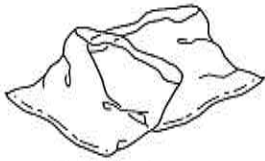

Plastic bags



Old clothes with holes



Old medicines



Newspapers

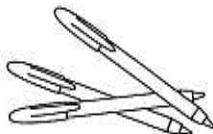
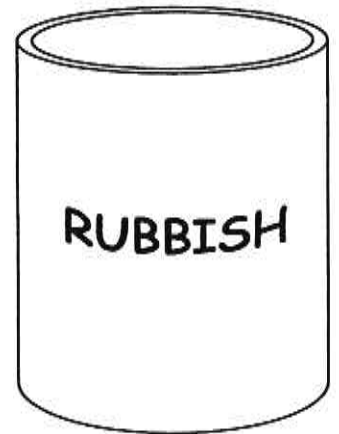

Old pens

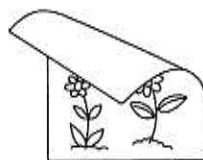

Drawing paper

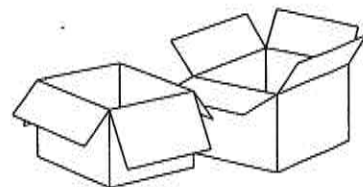

Cardboard boxes



Coat



Plastic cup

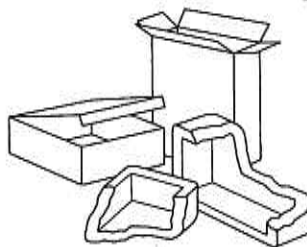

Packaging

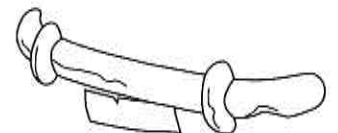

Scrap metal

# 4

## Heritage, Symbols and Songs



Label this map of the Cayman Islands. Colour the sea blue and the land green.

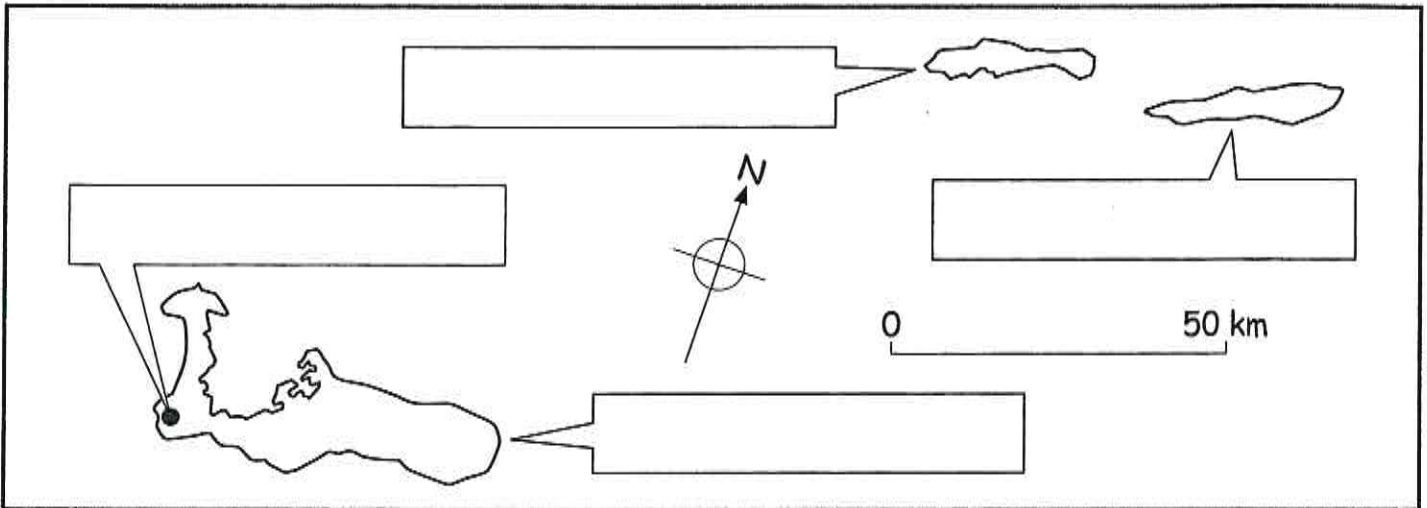

Draw your own map of the Cayman Islands. Mark on and colour the Districts. Label each District.

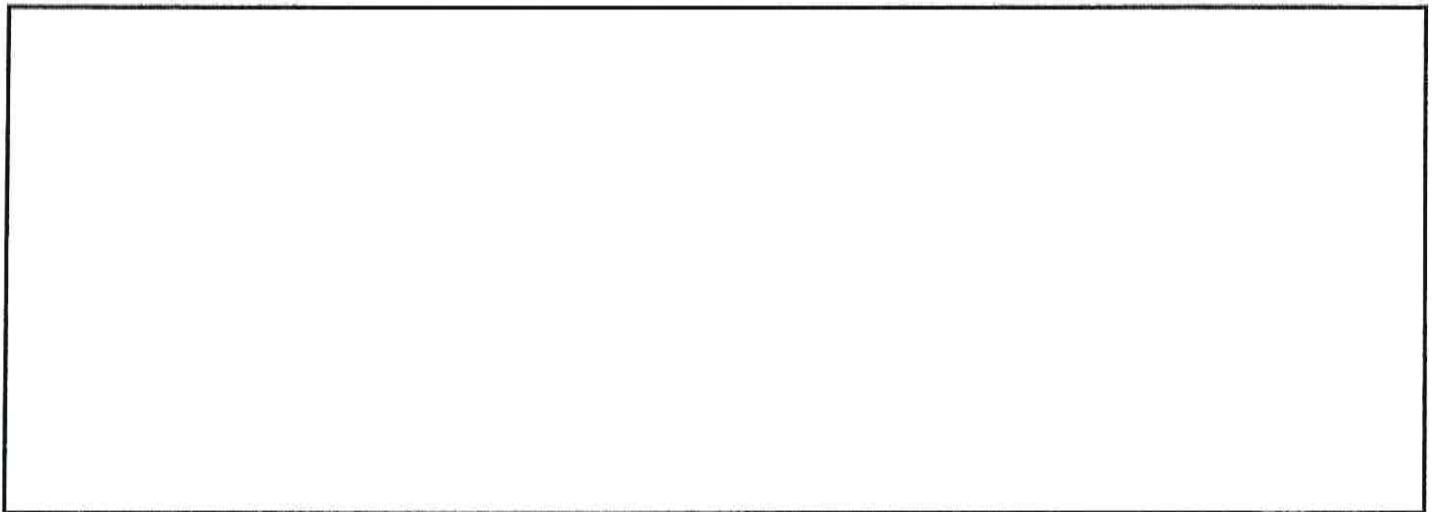

Use the Internet to find other maps of the Cayman Islands.

## Our history

What do you remember about our history?

Answer these questions.

- 1 Who discovered the Cayman Islands? \_\_\_\_\_
- 2 When did Columbus first come to the Caribbean? \_\_\_\_\_
- 3 What was the first name given to the Cayman Islands?  
\_\_\_\_\_
- 4 What animals were there in the sea around the Cayman Islands?  
\_\_\_\_\_
- 5 Why did ships stop at the Cayman Islands?  
\_\_\_\_\_
- 6 Who were the first people to live on the Cayman Islands?  
\_\_\_\_\_



Find out more about Columbus.

What kind of ships did he use? Why did he come to the Caribbean?

Draw a picture of Columbus sailing towards the Cayman Islands.

Match each of these words with its correct meaning.

Uninhabited (a) with lots of people living there  
(b) with no people living there  
(c) with turtles living there

Discovered (a) visited  
(b) sailed past  
(c) found for the first time

Wrecked (a) stayed there to live  
(b) destroyed – a ship broken up on the rocks  
(c) stopped to get turtle meat

Christopher Columbus first set sail from Spain in 1492. He discovered the Cayman Islands on his fourth voyage. In May 1503 his ships were blown off course by strong winds. He saw Cayman Brac and Little Cayman, but he did not land. There were so many turtles that he called the islands Las Tortugas.

Imagine you were Columbus. Write the entry for the ship's log.

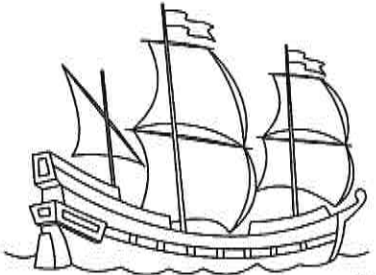
<b>Capitana</b>	10th May 1503
<hr/> <hr/> <hr/> <hr/> <hr/> <hr/> <hr/> <hr/>	
	



# National heroes

These people are national heroes of other countries.



Martin Luther King  
(USA)



Nelson Mandela  
(South Africa)



Florence Nightingale  
(UK)



Marie Curie  
(Poland/France)



Gandhi  
(India)



Marcus Garvey  
(Jamaica)



Find out what each of these people is famous for.  
Find their countries on a map of the world.

Name two national heroes of the Cayman Islands.

---

---

Write a sentence to describe the qualities of national heroes.

---

---

## Our National Festivals

Look carefully at the pictures on page 48 of your textbook.  
Write two sentences to explain what is happening in each picture.

The top picture shows \_\_\_\_\_

---

---

The middle left picture shows \_\_\_\_\_

---

---

The middle right picture shows \_\_\_\_\_

---

---

The bottom picture shows \_\_\_\_\_

---

---

Choose one festival. Draw a picture of what happens and write about it.

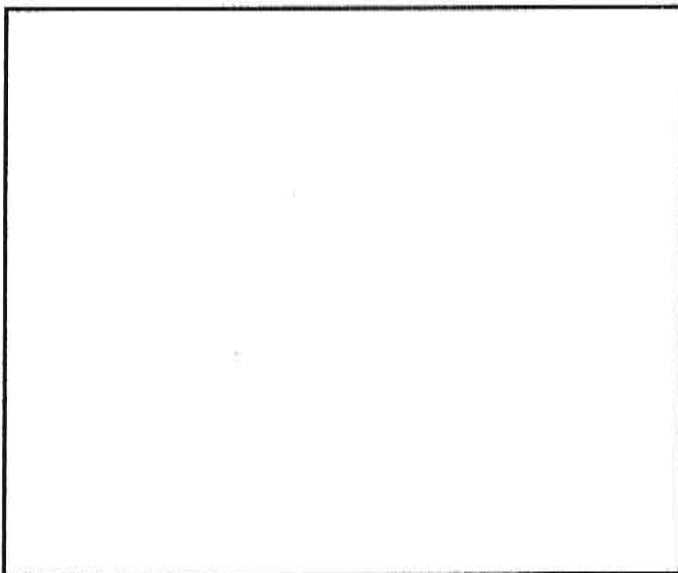

---

---

---

---

---

---

---

---

# Food during Pirates' Week

Draw your favourite Pirates' Week foods on the plate below.

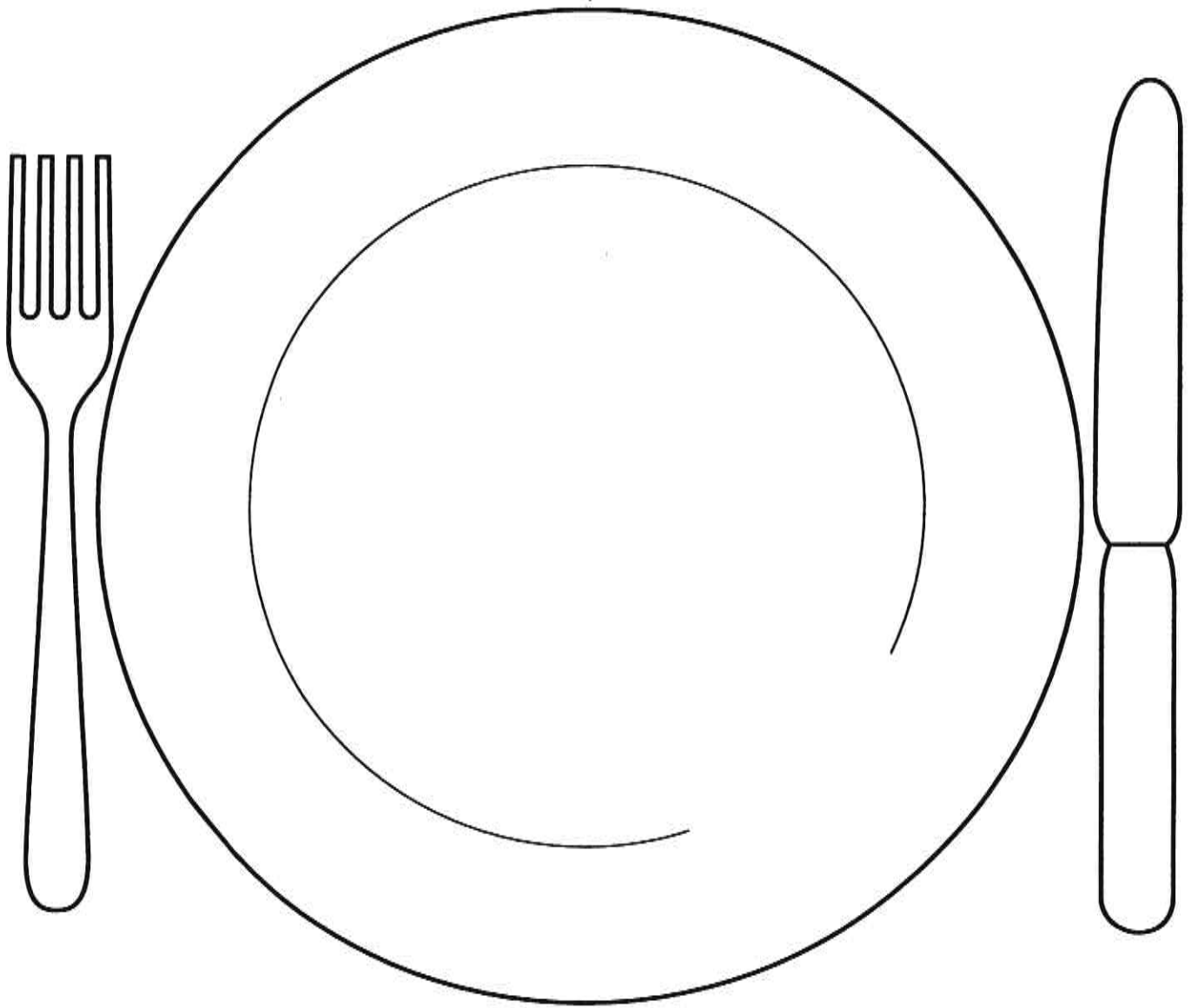

Colour and label the foods.



Activity

Find a recipe for your favourite food. Ask an adult to help you cook it. Bring it to class to share.

Talk about your favourite food and why you like it.

# Fun and games

Look at the pictures on page 50 of your textbook.



Find out the names of the three games being played. Write them here.

---

---

Name two of the musical instruments being played.

---

What is the name of the dance shown on page 50 of your textbook?

---



Ask older people about the games they used to play when they were young. List them below.

---

---

Choose one game that the older people used to play. Ask them to teach you. Write the instructions below or word process them, print them out and stick them here. Teach your friends to play the game.

---

---

---

---



---

---

---

# Our National Symbols

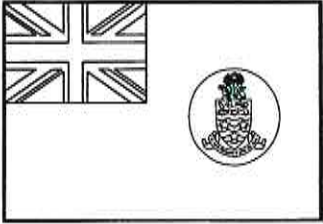
Look around school and in the community to find the Cayman Islands flag and the Coat of Arms. Fill in the table below to record where you have found them and how many you have found.

	Where found	Total
<p>Cayman Islands flag</p>  <p>Coat of arms</p> 		

The motto on the coat of arms says: 'He hath founded it upon the seas.'

Who do you think the 'He' is? \_\_\_\_\_

What do you think the 'it' is? \_\_\_\_\_

Why is our coat of arms important?



The Cayman Islands flag flown on ships is slightly different to the flag flown on land. Find out what the difference is.

# Plants and animals

These plants and animals live in the Cayman Islands. Draw a line from each one to its name and colour it.

Grand Cayman parrot

Cayman Brac parrot

Hawksbill turtle

Blue iguana

Banana orchid

Silver thatch palm

Periwinkle

Cow-itch vine

Ironwood tree

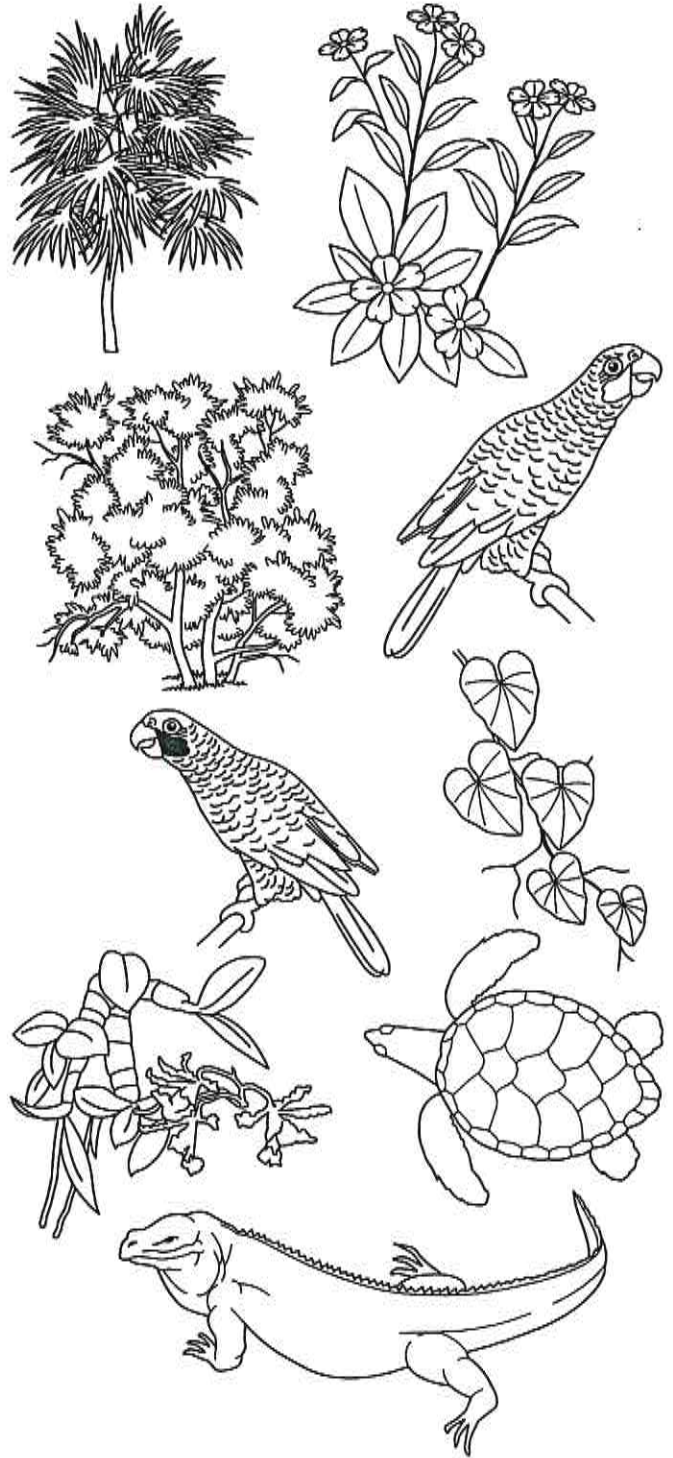

Circle those that are national symbols.

Put an X against those that are not national symbols.

# Our National Anthem and Our National Song

Read our National Anthem on page 53 of your textbook.

The words below come from our National Anthem.

Ask an adult or use a dictionary to find out their meanings. Write the meaning by each word.

Noble

---

Victorious

---

Glorious

---

Reign

---

Read our National Song on page 53 of your textbook.

Draw a picture to show the scene described by the first verse. Colour your picture. Label the picture using descriptive words from the song (see the box below).

land    verdant trees    sea    palest em'erald    darkest blue

Activity

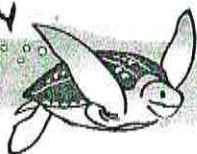

Make a list of descriptive words used in the National Anthem and in the National Song. Put these words and their meanings on the bulletin board.

Cut out the words and pictures. Stick them in the correct places on page 32.

Street cleaner

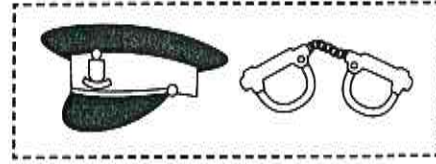

Police officer

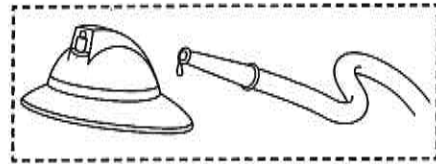

Nurse

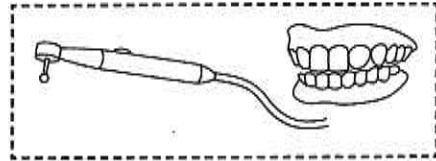

Fireman



Dentist

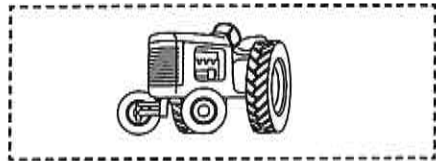

Teacher

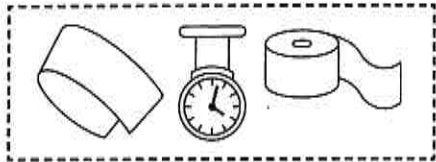

Farmer





MACMILLAN

# CAYMAN

## Primary Social Studies

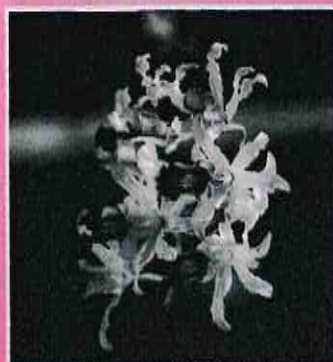

Cayman Primary Social Studies Workbooks 1–6 have been written to accompany the Cayman Primary Social Studies Textbooks 1–6 and each Workbook closely follows the scheme of work suggested by the Social Studies Curriculum Guide and its Learning Outcomes for the year.

The Workbooks build on the work in the Textbooks and activities in the Teacher's Guides, allowing practise of skills and revision of knowledge. They can be used by teachers in the classroom or to provide homework tasks for the children.

[www.macmillan-caribbean.com](http://www.macmillan-caribbean.com)



ISBN 978-0-333-98805-3



9 780333 988053