

# CAYMAN

## Primary Social Studies

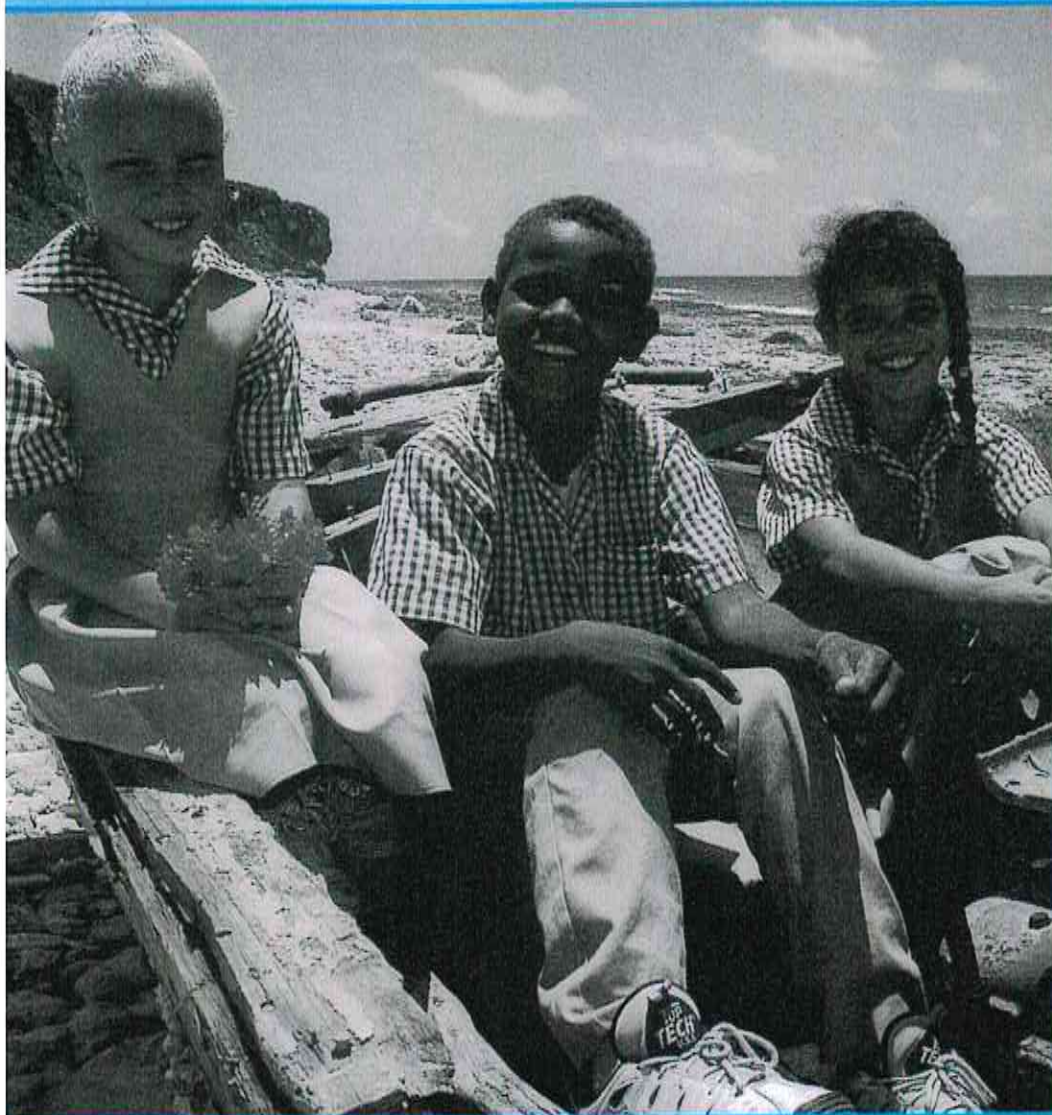

WORKBOOK **1**

**Cayman Islands**  
**Primary Social Studies**

WORKBOOK 1



Macmillan Education  
Between Towns Road, Oxford OX4 3PP  
A division of Macmillan Publishers Limited  
Companies and representatives throughout the world  
www.macmillan-caribbean.com

ISBN: 978-0-333-98804-6

Text © Education Department, Cayman Islands 2003  
Design and illustration © Macmillan Publishers Limited 2003

First published 2003

All rights reserved; no part of this publication may be reproduced, stored in a retrieval system, transmitted in any form or by any means, electronic, mechanical, photocopying, recording, or otherwise, without the prior written permission of the publishers.

Typeset by J&D Glover Ltd  
Illustrated by David Woodroffe  
Cover design by Gary Fielder, AC Design  
Cover photograph by Andrew Guthrie

The authors and publishers would like to thank the following for permission to reproduce their photographs:  
Education Department, Cayman Islands

The publishers have made every effort to trace all the copyright holders, but if they have inadvertently overlooked any, they will be pleased to make the necessary arrangements at the first opportunity.

Printed and bound in Malaysia

2010 2009 2008 2007  
13 12 11 10 9 8 7 6 5 4 3

## **Contents**

Theme 1	Myself	4
Theme 2	My Family	13
Theme 3	My School	25
Theme 4	My Country	33
Cut-out pages		45



# 1

# Myself



Who am I?

Fill in the blanks.

My name is \_\_\_\_\_ . I am a \_\_\_\_\_ .

I am \_\_\_\_\_ years old. My birthday is \_\_\_\_\_ .

Draw a picture of yourself.

Draw lines from the labels to your body parts.

head

hair

eyes

arms

hands

trunk

legs

feet

Write three things about yourself.

---

---

---

Draw lines to match Bob and Pam with what they are saying.



My name is Pam.

I am a girl.

I am five years old.

I am a boy.

I am six years old.

My name is Bob.

Now label the parts of Bob's body. Use words from the box below.

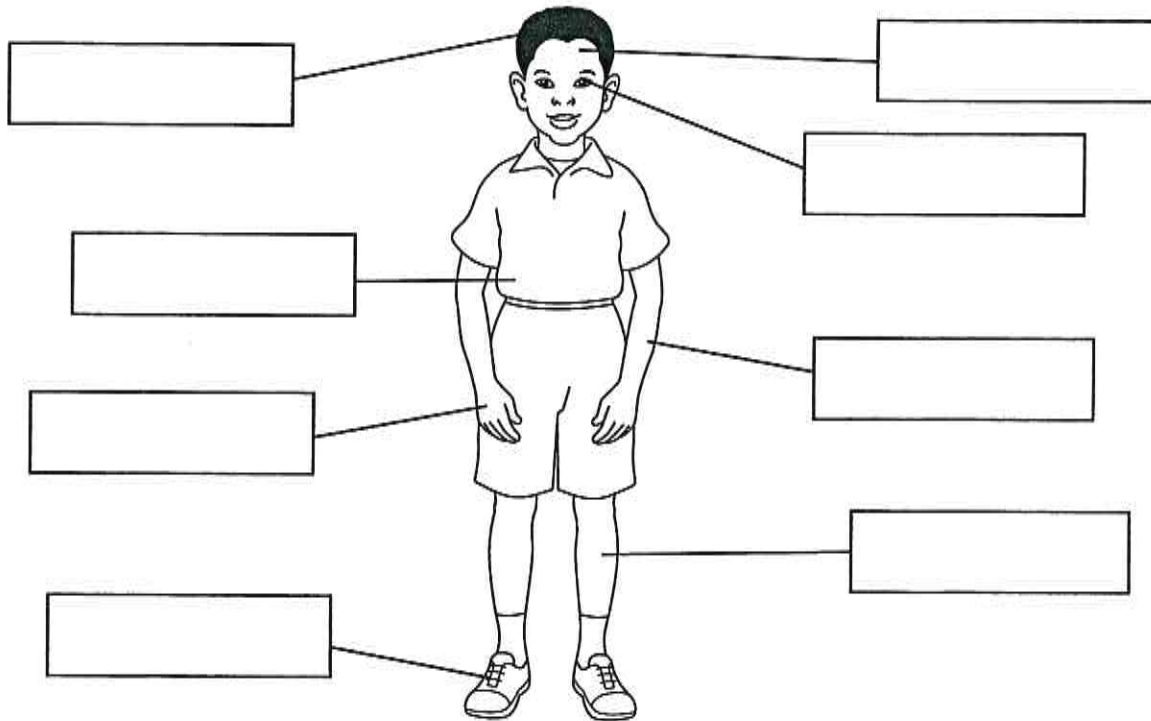

head   arm   leg   trunk   hand   foot   hair   eye

# My body

With a friend, measure your body parts. Write in the measurements.

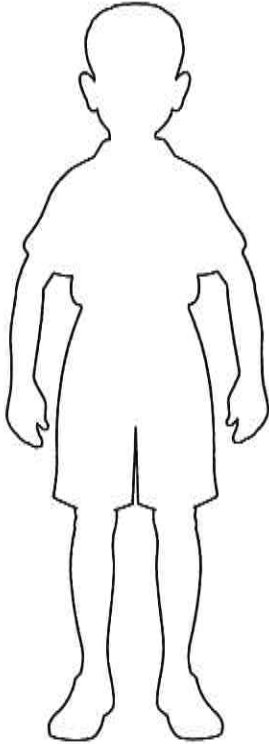

I am \_\_\_\_\_ cm tall.

My arms are \_\_\_\_\_ cm long.

My legs are \_\_\_\_\_ cm long.

Draw and colour in your hair and eyes. Write in the colours.

My hair is \_\_\_\_\_ .

My eyes are \_\_\_\_\_ .

Now count your body parts. Write the numbers in the blanks.

I have \_\_\_\_\_ arms.

I have \_\_\_\_\_ head.

I have \_\_\_\_\_ fingers.

I have \_\_\_\_\_ feet.

I have \_\_\_\_\_ eyes.



# My senses

Fill in the blanks.



I hear sounds with my \_\_\_\_\_.



I see things with my \_\_\_\_\_.



I smell things with my \_\_\_\_\_.



I taste food with my \_\_\_\_\_.

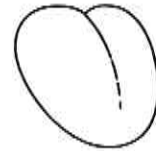

I feel things with my \_\_\_\_\_.

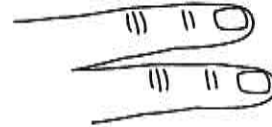

Activity

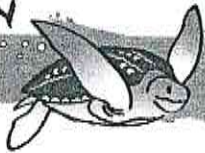

Use a mirror.

Draw a picture of your own head.

Label the sense parts.



# The same and different

These children look the same in some ways. They look different in some ways.

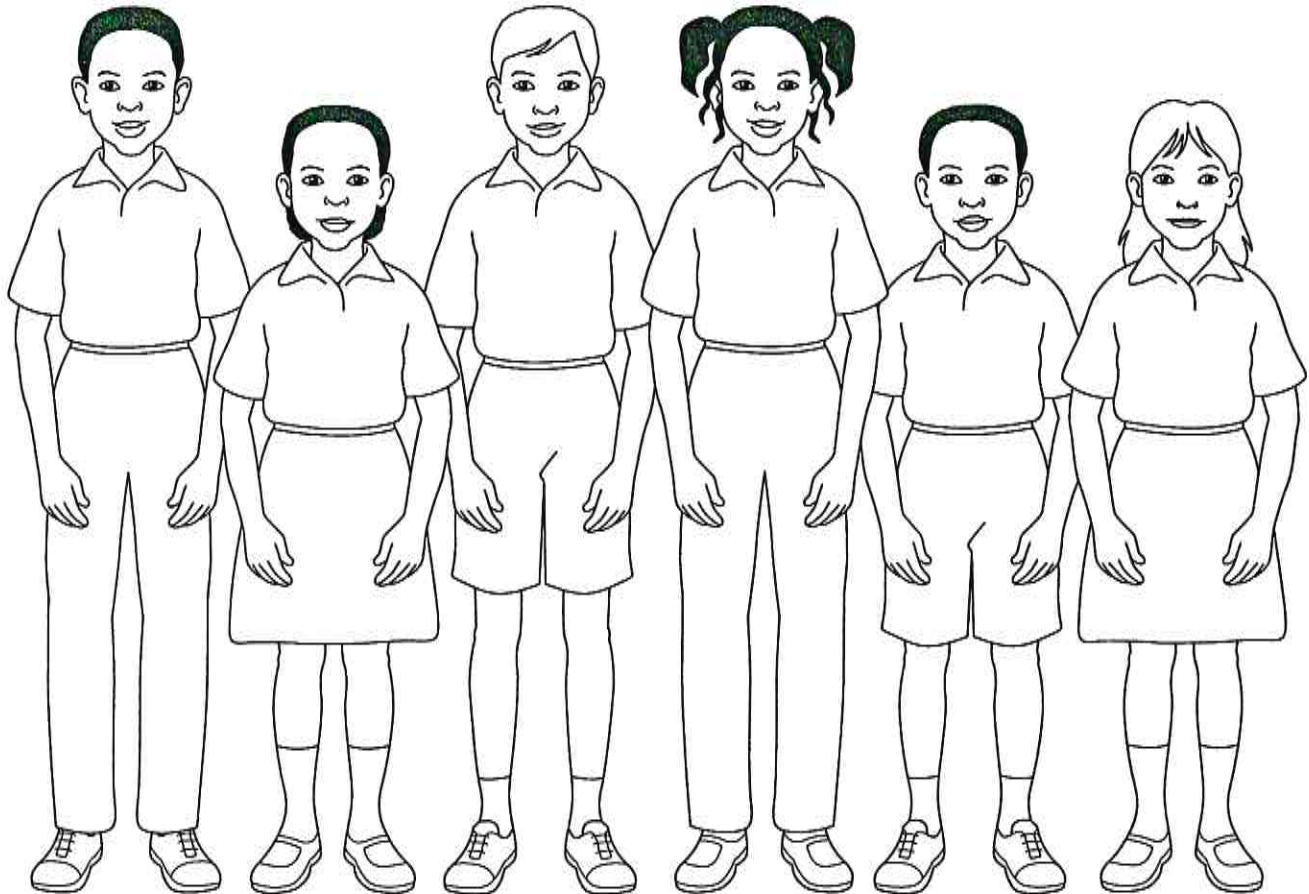

Mark the girls with a tick. ✓

Mark the tall children with a circle. ○

Mark the children with dark hair with an X. ✕

Mark the children wearing pants with a square. □

Talk about the pictures with a friend. What other things are the same? What differences can you see?

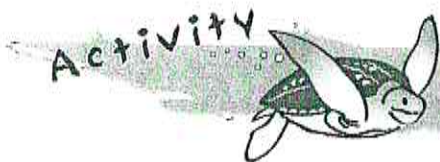

On a sheet of paper draw pictures of the children in your class.

How many children are there in your class?

# Feelings

Match, stick and colour. See page 45.

angry



ill



happy

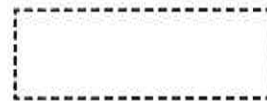

hungry



sad

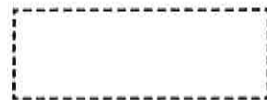

Draw your face and write how you feel today.

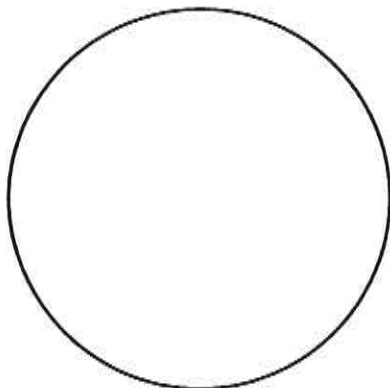

# Things we like to do

Cross out the words to show what you like doing and what you don't like doing.



I like/don't like swimming.



I like/don't like reading.



I like/don't like playing football.

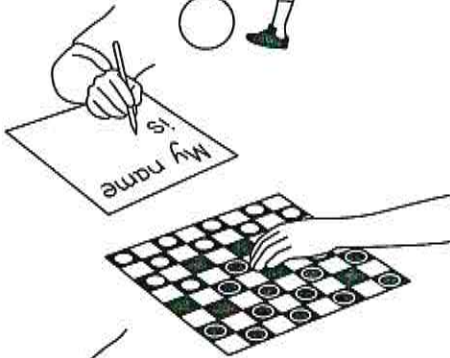

I like/don't like writing.

I like/don't like playing games.

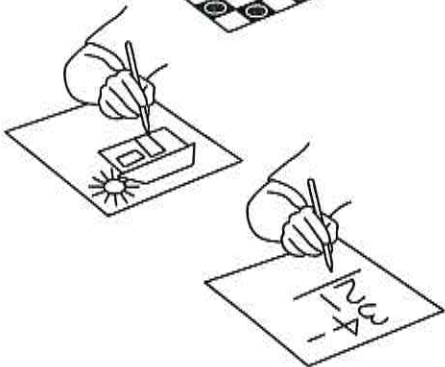

I like/don't like drawing.

I like/don't like doing sums.



What things do you like to do at school?

---

---

---

Draw pictures to show four things you like doing.  
Write the doing words underneath. Use words from the box.

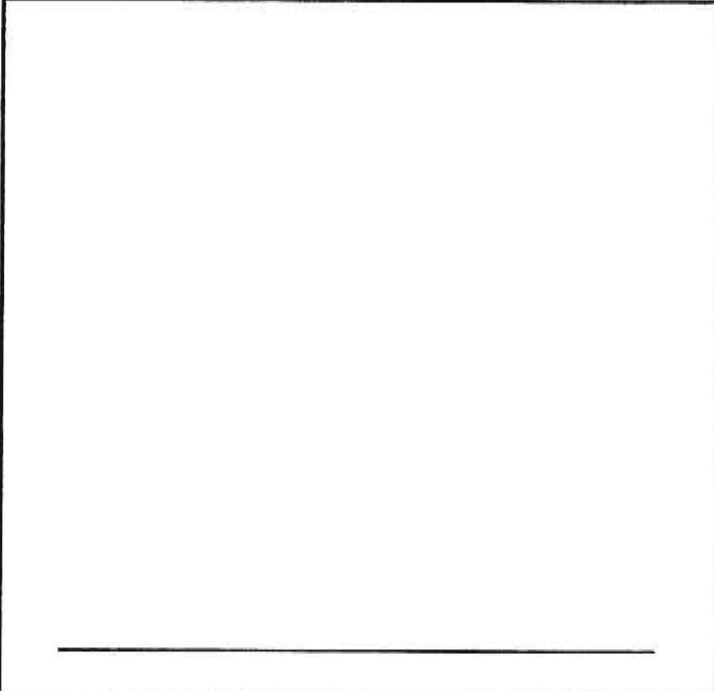
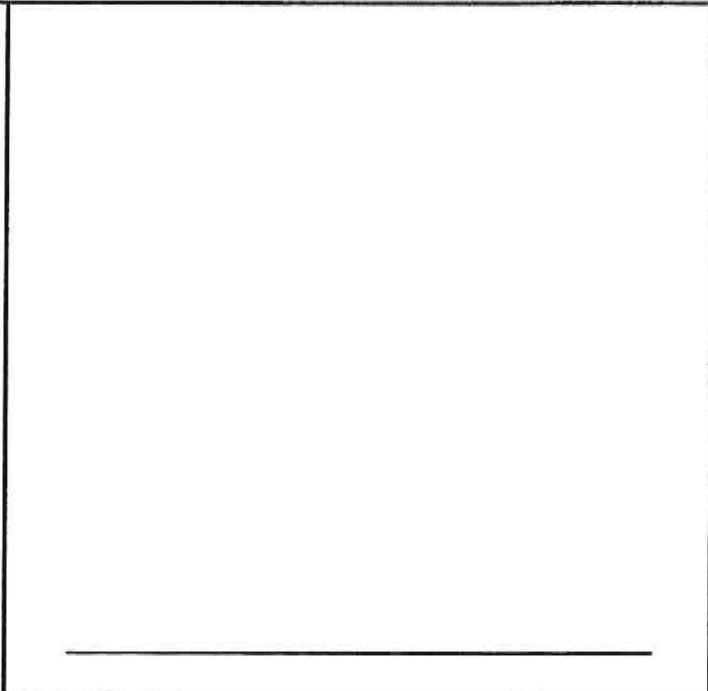
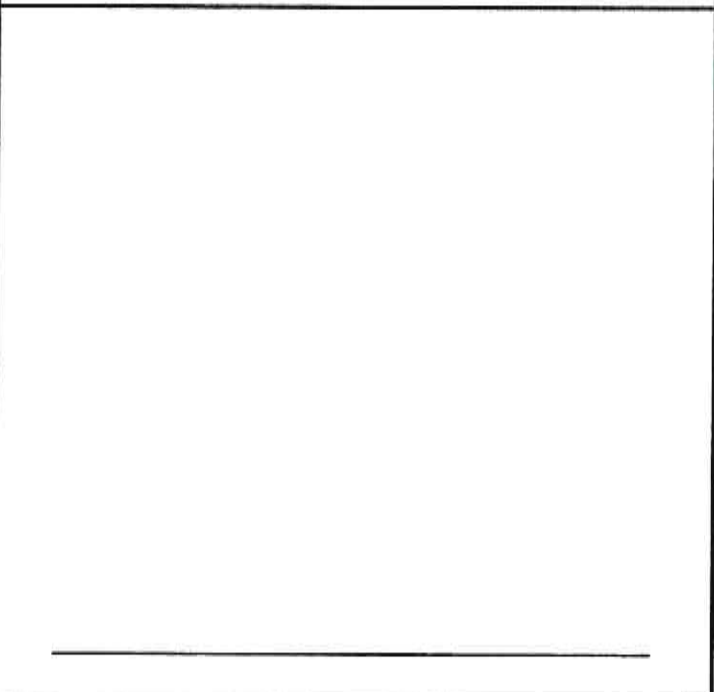
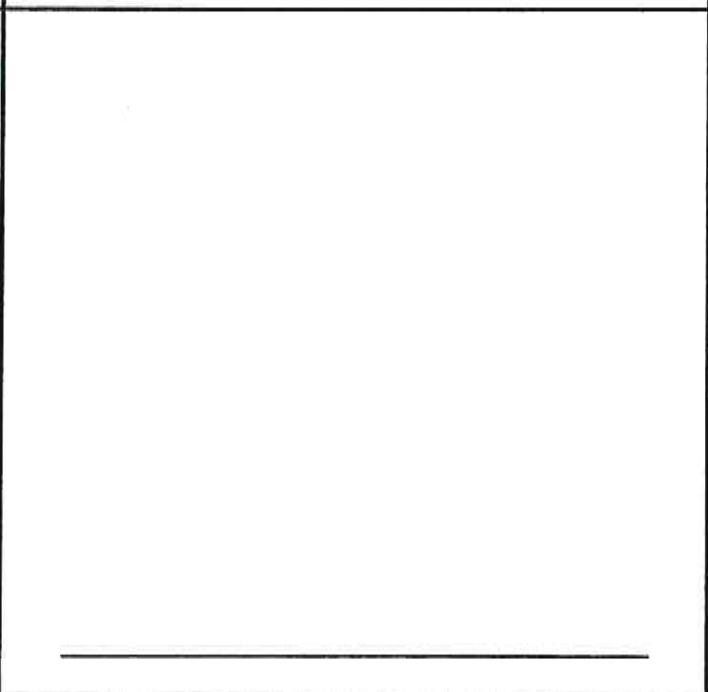
 _____	 _____
 _____	 _____

- swimming
- writing
- eating
- cycling
- playing football
- running
- fishing
- drawing
- reading
- playing games
- doing sums



Pam has drawn a time line of her life.

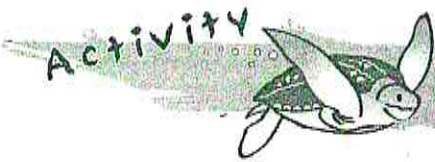
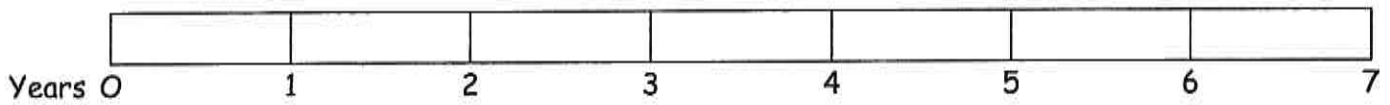

Draw pictures on the time line below to show your life.

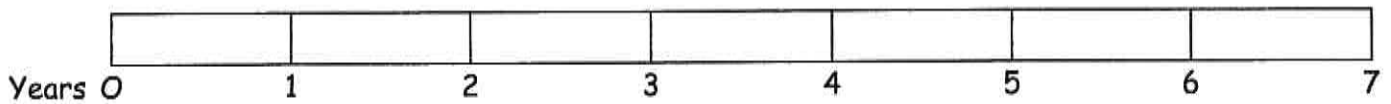

# 2 My Family



This is Bob's family.  
Draw lines to match the labels to the people.

Grandad

Grandma

Sister

Bob

Dad

Mom

Brother

Sister

A collection of line drawings of people's faces, arranged in two rows. The top row contains four faces: an elderly man, a man, a woman, and a woman with braids. The bottom row contains four faces: a woman, a young girl, a young boy, and a young girl in profile.

## Activity

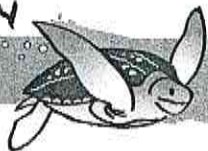

Draw a picture of your family. Label the people.

# Family trees

This is Bob's family tree.

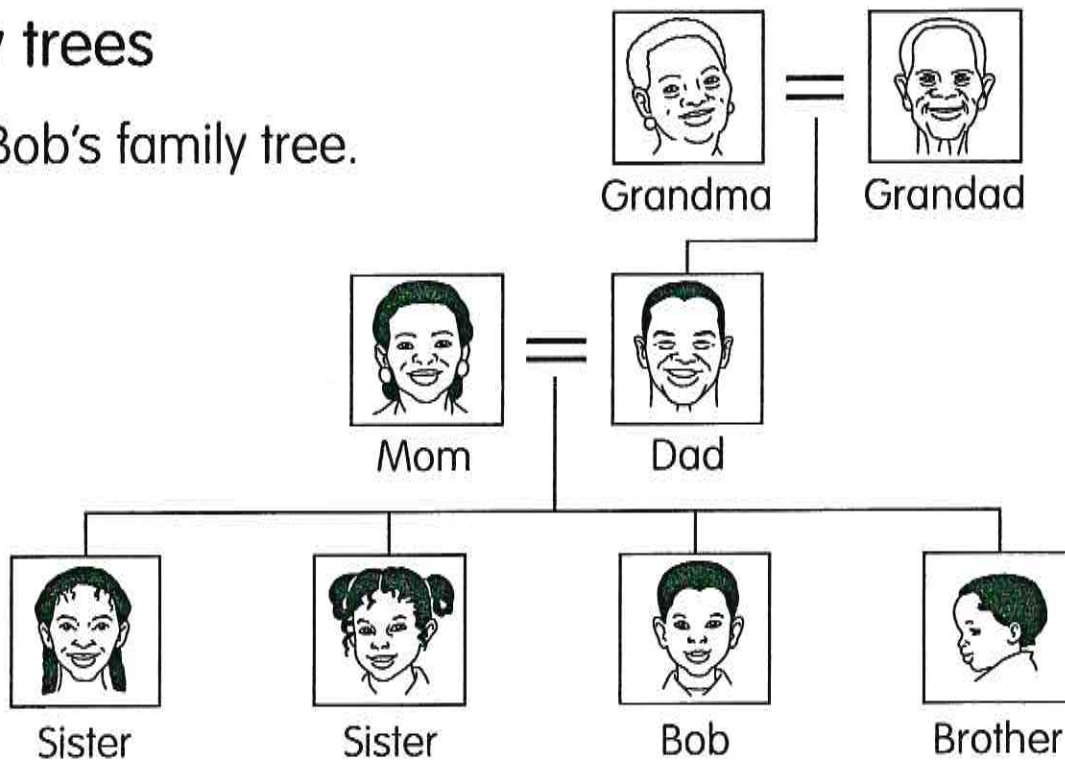

Draw your family on the family tree below.  
Label the people.

## My family tree

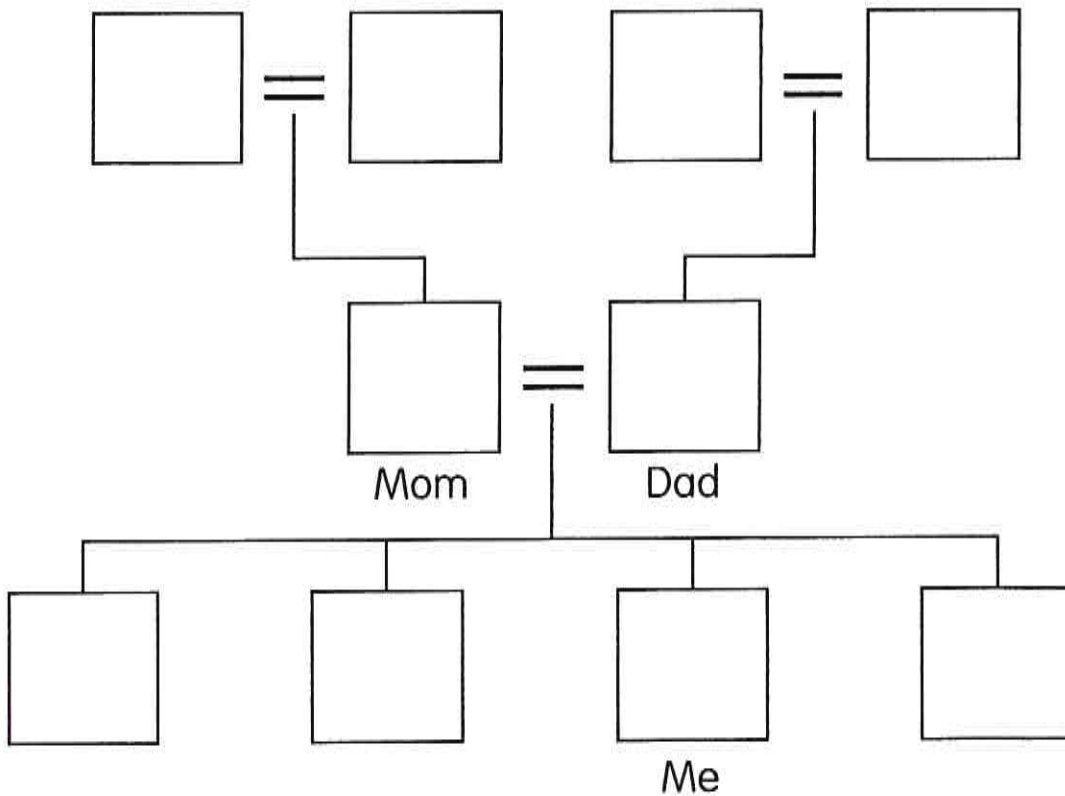

# Kinds of families

Write how many people are in each family.

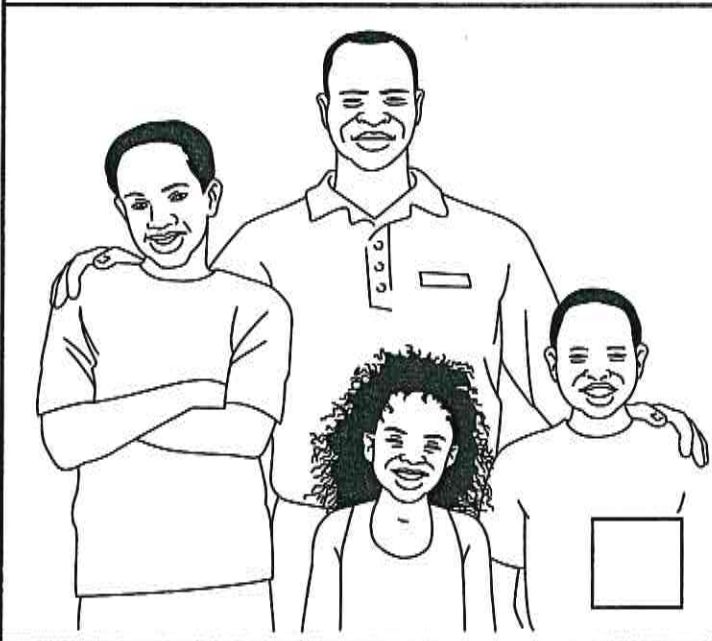
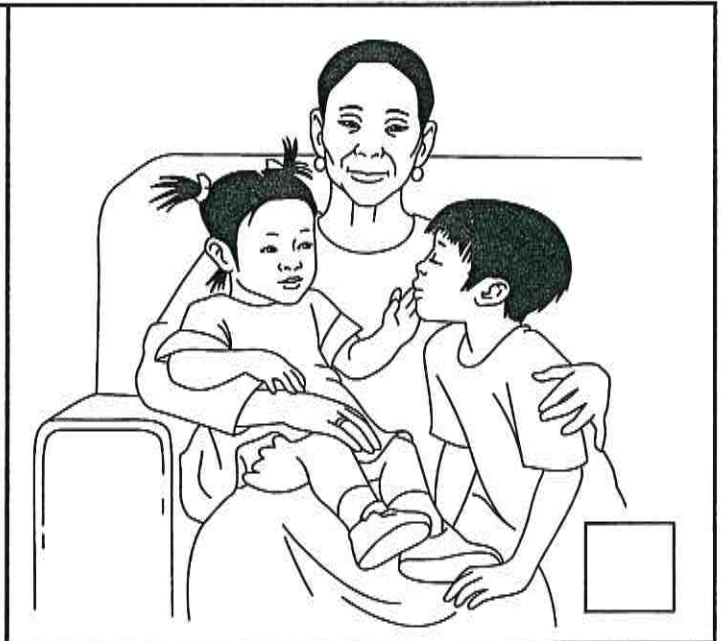

Talk with a friend. Say who the people are in each family.  
Which families are big? Which families are small?

How many people are there in your family?



# Our needs

Draw lines to match the pictures with the sentences.

We need food to eat.

We need water to drink.

We need air to breathe.

We need a house to live in.

We need clothes to wear.

We need love and care.



Write who gives you what you need.

---

---

---

---

---

---

Look carefully at this picture. Circle the things we really *need*.

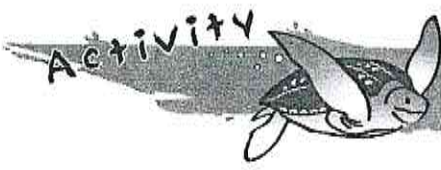

Draw your favourite food and drink.

# Parents' jobs

Write the correct word with each job. Use words from the box.

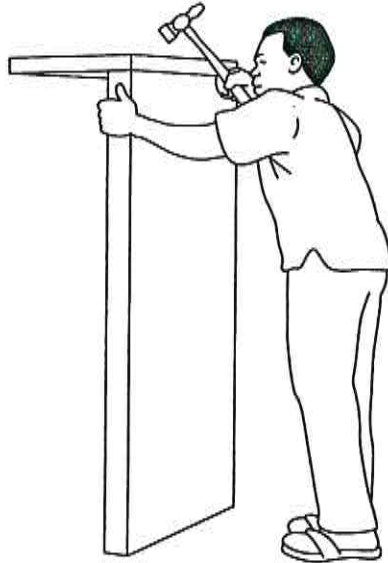

plumber  
bank clerk

carpenter  
bus driver

hotel worker  
teacher  
cook

What job does your Mom or Dad do?

My Mom/Dad is a \_\_\_\_\_.

# Addresses

Pam has a letter from her Grandma. It has Pam's address on it.



Write your name and address here:

---

---

---

---



# Our homes

This is Bob's house.

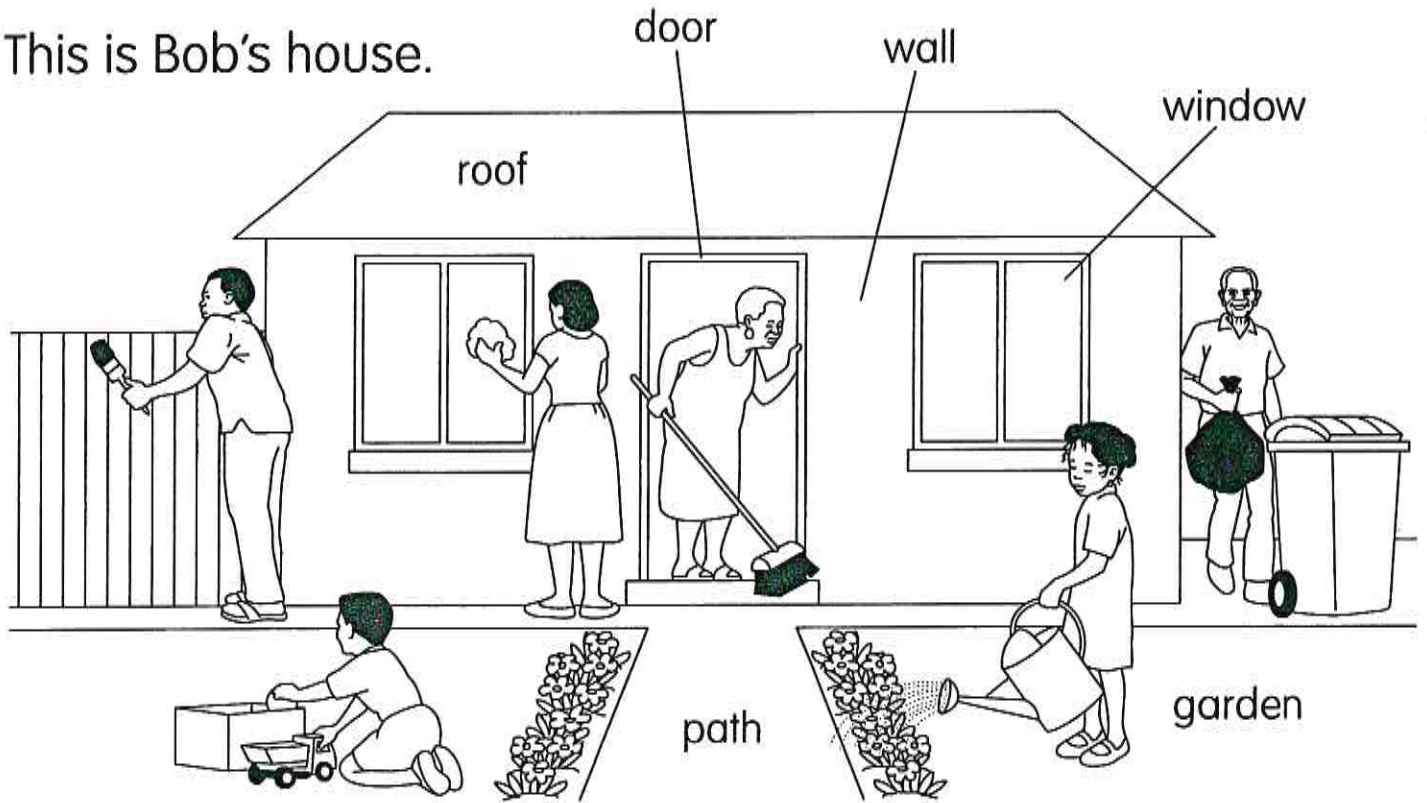

Talk about this picture with a friend. What are Bob's family doing? What jobs need to be done inside the house?

Activity

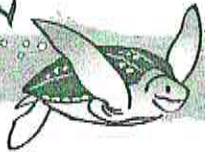

Draw a picture of your house. Write on labels.

# In my house

Cut out the labels from page 47. Label the rooms below.

Cut out the furniture from page 47. Stick it in the correct rooms.

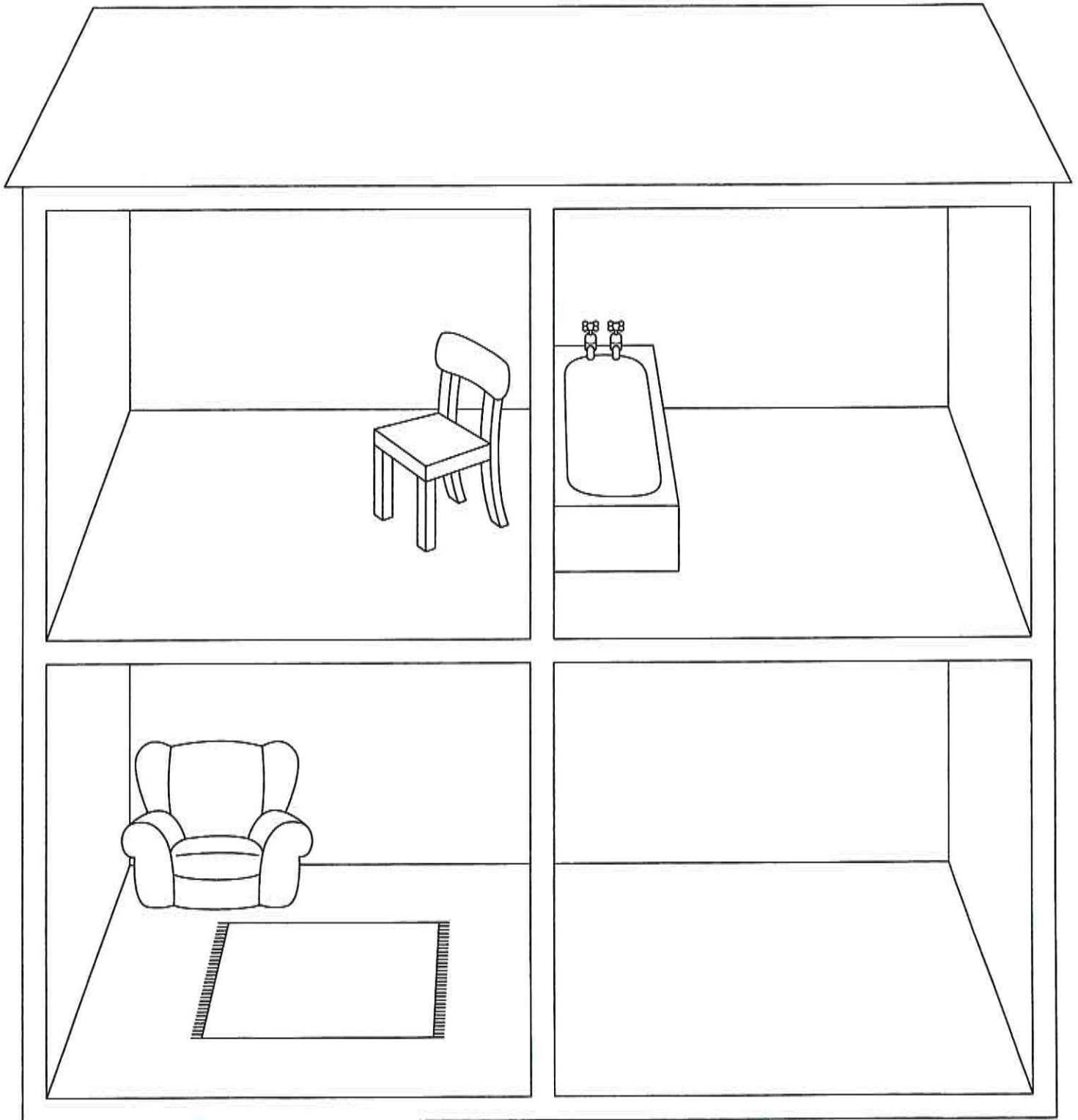

Families do things together.

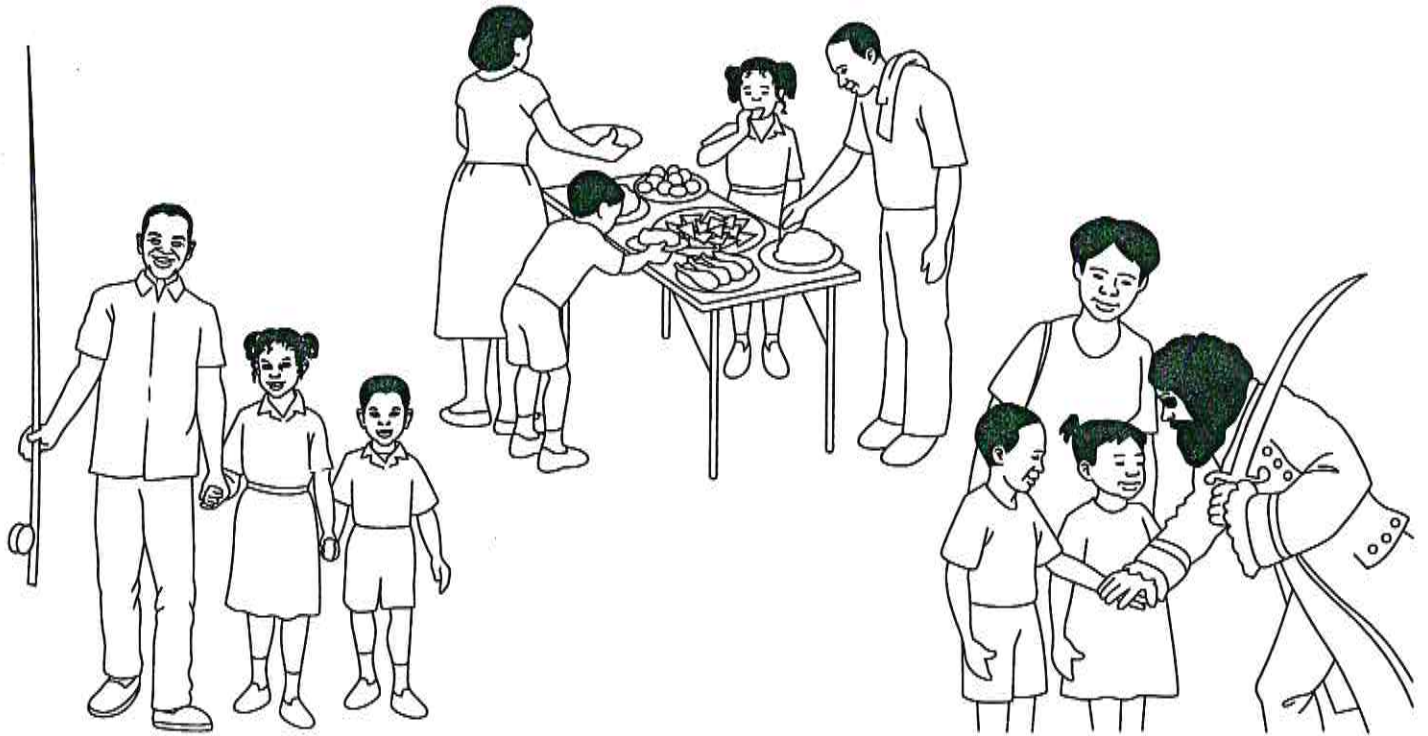

Talk about these pictures with a friend. What is happening?

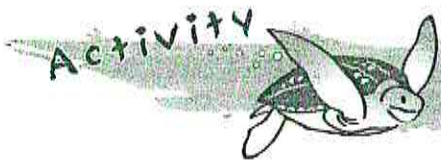

Draw a picture of something you like to do with your family.

Talk about your picture with a friend.

# Danger!

This house is dangerous. Mark the dangers you can see with an **X**.



Talk about how to make the house safe.



# Rules at home

Match the pictures with the sentences.

Be kind to others.



Keep the house tidy.



Help parents with jobs at home.

Look after small children.



Look after animals.

Write two rules that you have at home.

---

---

Theme

# 3

## My School

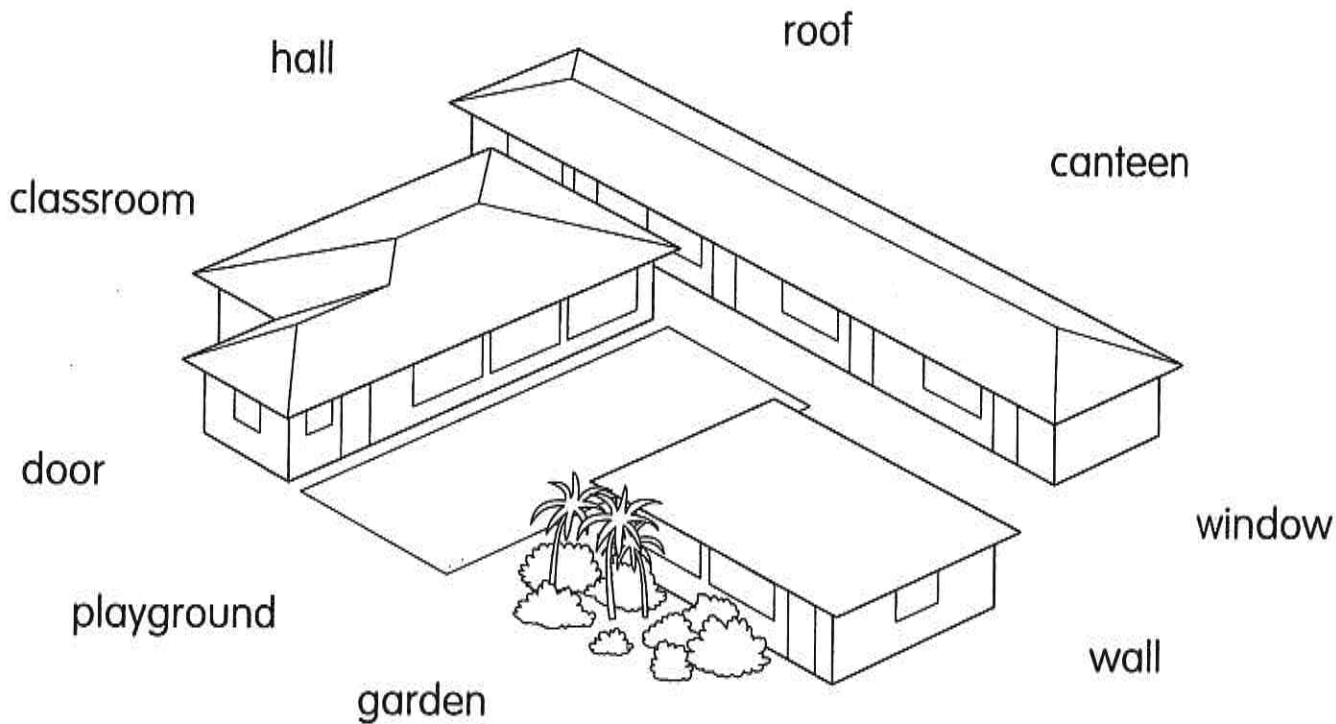

Draw a line from each word to label this picture correctly.

Activity

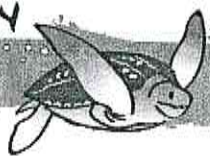

Draw a picture of your own school and label it.

# People at school

These are some of the people at Pam and Bob's school.  
Use the words in the box below to write in the blanks.

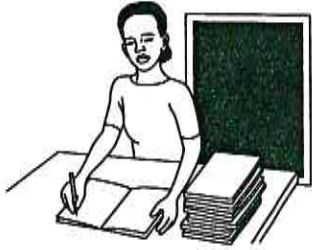

Mrs Jones is a

---



Mrs Tibbetts is the

---



Mr Roberts is the

---



Mr Ebanks is the

---



Mrs Slater is the

---

teacher    cook    caretaker    school bus driver    principal

What is your teacher's name? \_\_\_\_\_

Activity

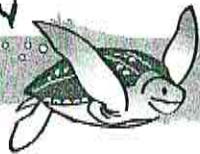

Draw a picture to show some of the people at your school. Write their names.



# Things we do at school



We listen to stories.

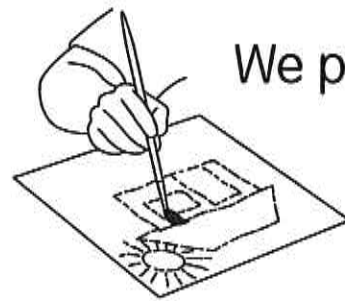

We paint pictures.



We play music and sing.



We have assembly.



We cook food.

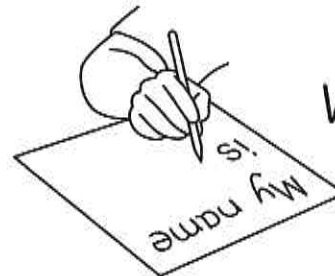

We write.

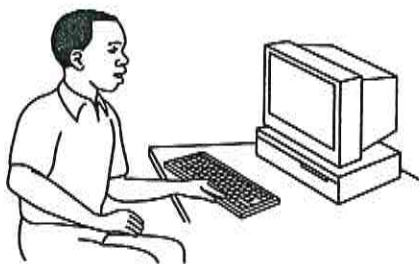

We use the computer.

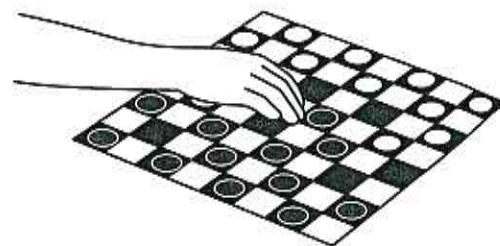

We play games.

Choose two things you like to do at school. Copy two of the sentences or write your own.

---

---



# School rules

Pam and Bob's school has these rules:

Be kind to others.

Do not fight.

Be polite to teachers.

Do not run indoors.

Do not drop litter.

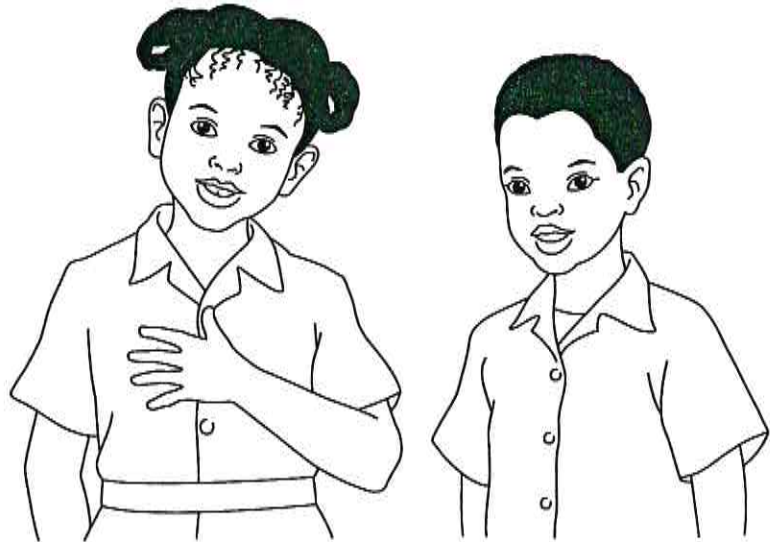

Draw pictures to show two school rules.

Write the rule underneath each picture.

<hr/> <hr/>	<hr/> <hr/>
-------------	-------------

# On the way to school

Pam and Bob see many things on their way to school. Fill in the blanks.

Pam and Bob pass many \_\_\_\_\_  on

the way to school. They see \_\_\_\_\_ 

and \_\_\_\_\_ . They walk past a restaurant

and a \_\_\_\_\_ 

They see some shops, a \_\_\_\_\_ 

and a \_\_\_\_\_ . They also see

 \_\_\_\_\_ and people.

Write one sentence about something you see on the way to school.

---

---

Draw a picture to show the things you see on the way to school. Label some of the things you see. You can use words from the box below.

road cars the sea houses supermarket  
shops trees bushes flowers restaurant  
gas station traffic lights church people walking

## Traffic signs

Draw these traffic signs. You can find them on pages 24 and 25 of your textbook.

No entry	Stop	Pedestrian crossing
Traffic lights	School crossing	

Colour the signs correctly.



# Road safety

Draw a picture to go with each road safety rule.

1 Walk on the sidewalk.

2 Stop, look, listen and think before you cross the road.

3 Use the pedestrian crossing.

4 Wear a helmet when you cycle.

# 4 My Country

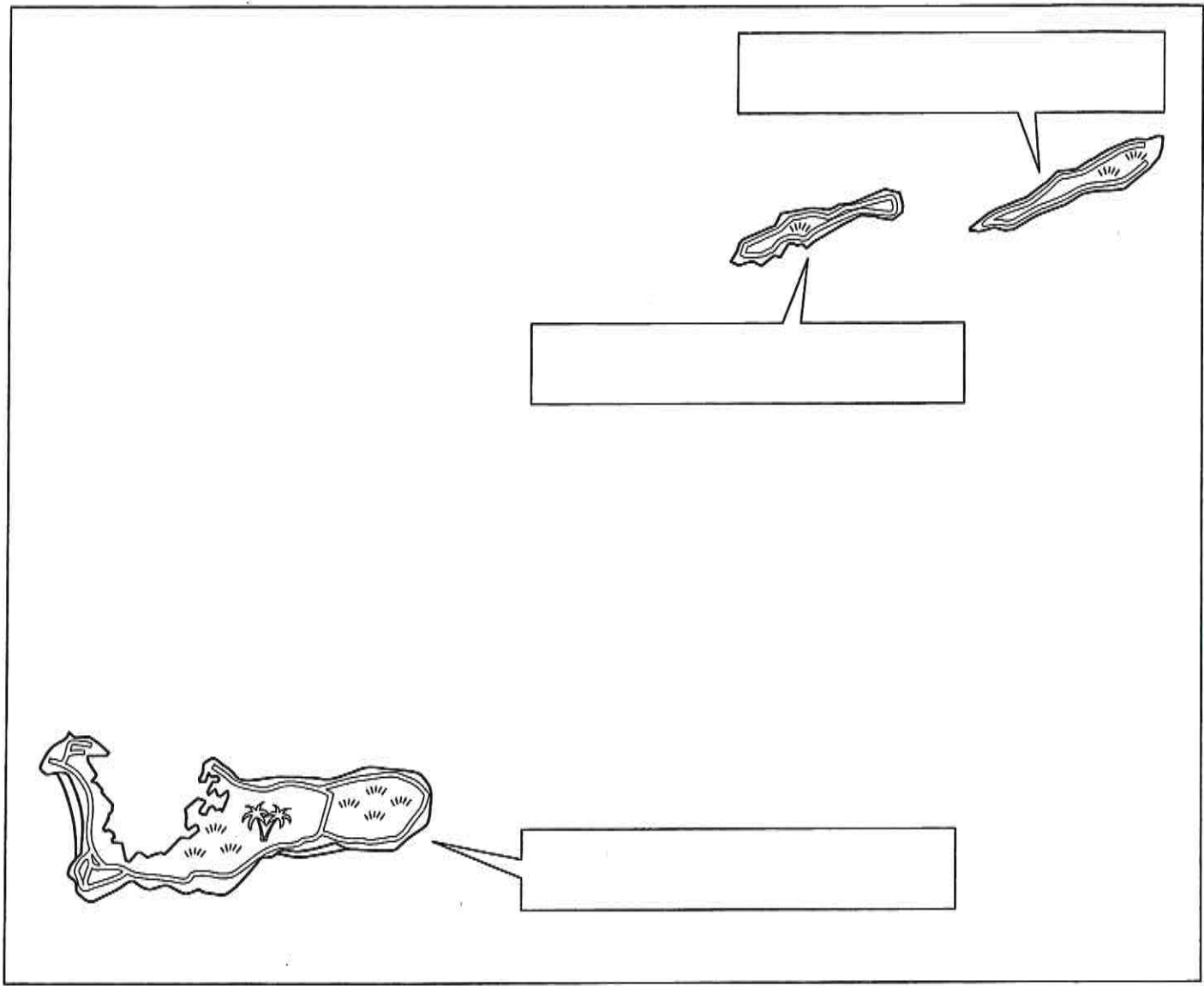

Label each island with its name.

Colour the land green. Colour the water blue. Colour the beaches yellow.

Mark on George Town and label it.

Label the Caribbean Sea.

# The Cayman Islands

Fill in the blanks in these sentences.

I live in the \_\_\_\_\_ Islands.

I live on \_\_\_\_\_ Island.

An \_\_\_\_\_ is land with water all around it.

Grand Cayman is the \_\_\_\_\_ of the three islands.

\_\_\_\_\_ is the smallest of the three islands.

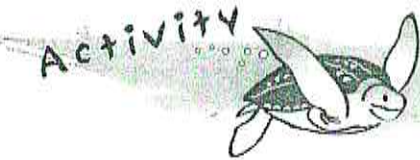

Draw a picture of an imaginary island.  
Colour the sea blue and the land green.  
Draw on any trees, houses and other things you would like.  
Give your island a name.

# Things Caymanians like to do

Match the pictures to the sentences.

We like to dance.

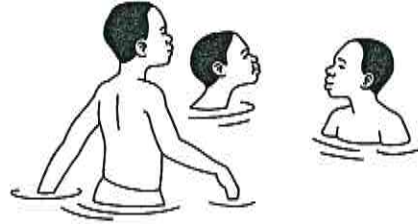

We like to go on picnics.

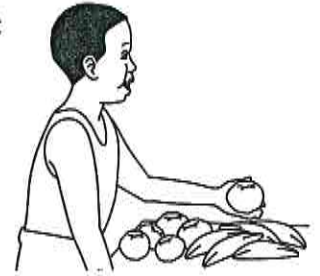

We like to dress up.



We like to go to church.



We like to shop.



We like to play ball games.



We like to swim.



We like to fish.

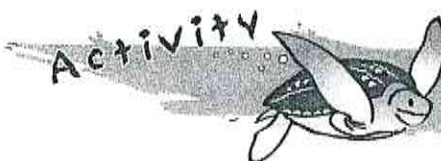
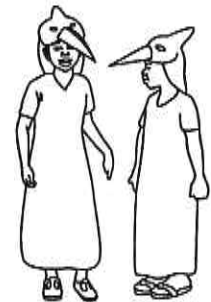

On a sheet of paper, draw something you like to do. Write a sentence underneath.



# Visitors to the Cayman Islands

How could you help these tourists? What could you say?

Please could you tell us the way to the supermarket?



What time does the bank open please?



Is there anywhere near here where I can find a room please?



Where can we play football please?



Practise your answers with a friend.

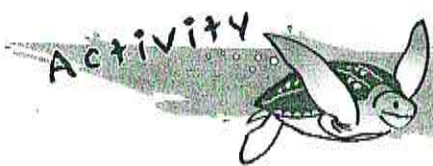

Collect pictures of things in your neighbourhood that tourists might like. Cut them out and stick them to a large sheet of card to make a big picture.

# Foods Caymanians like to eat

Match the words to the pictures.

Turtle stew



Lobster

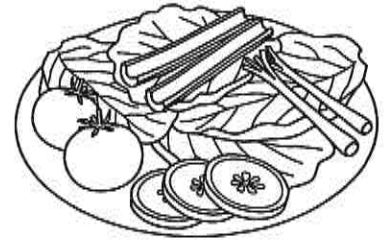

Bananas

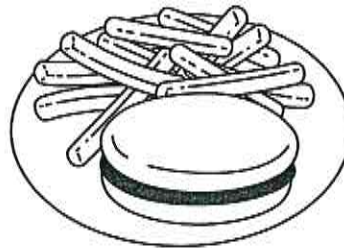

Baked chicken

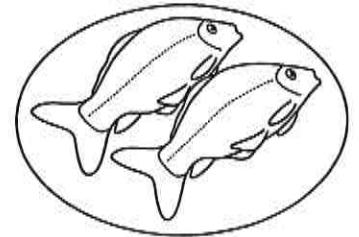

Salad

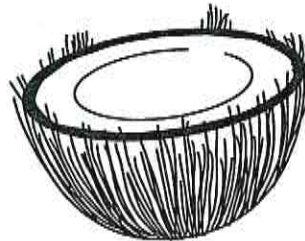

Coconut

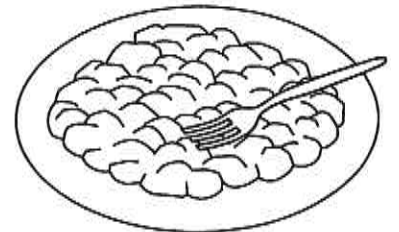

Fish



Burger and chips

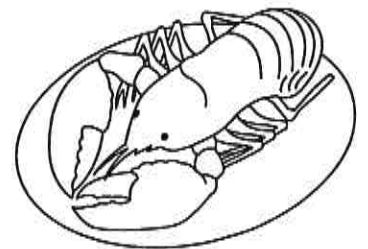

Tick the foods you like best. ✓

Circle the foods that are special to the Cayman Islands.

# Foods from the land and from the sea

Draw pictures in these boxes to show foods that come from the land and from the sea.

## *Foods from the land*

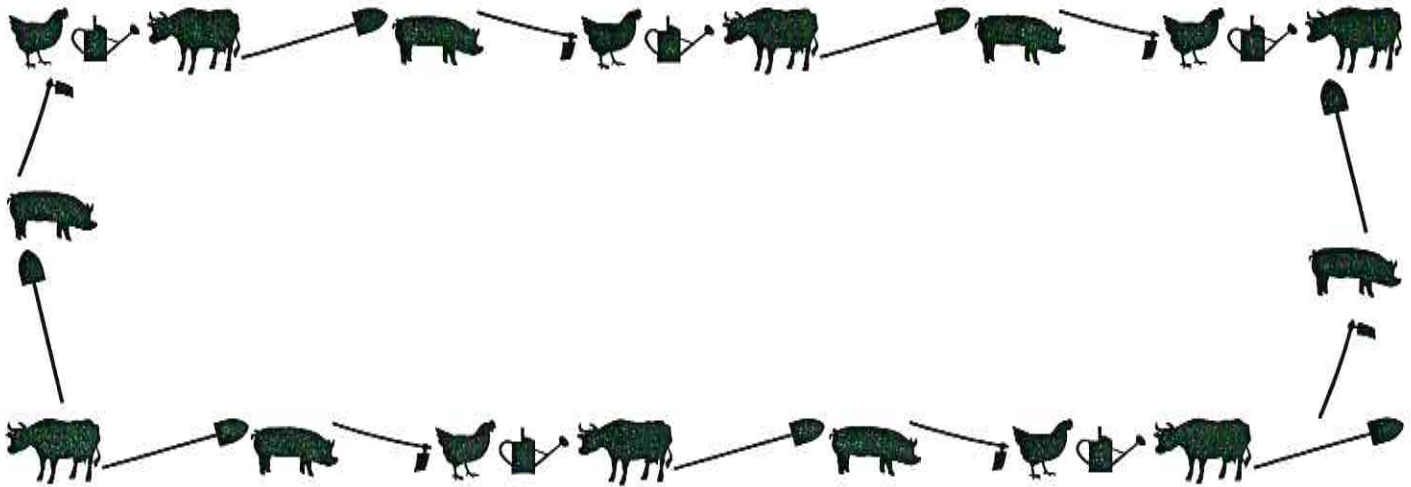

## *Foods from the sea*

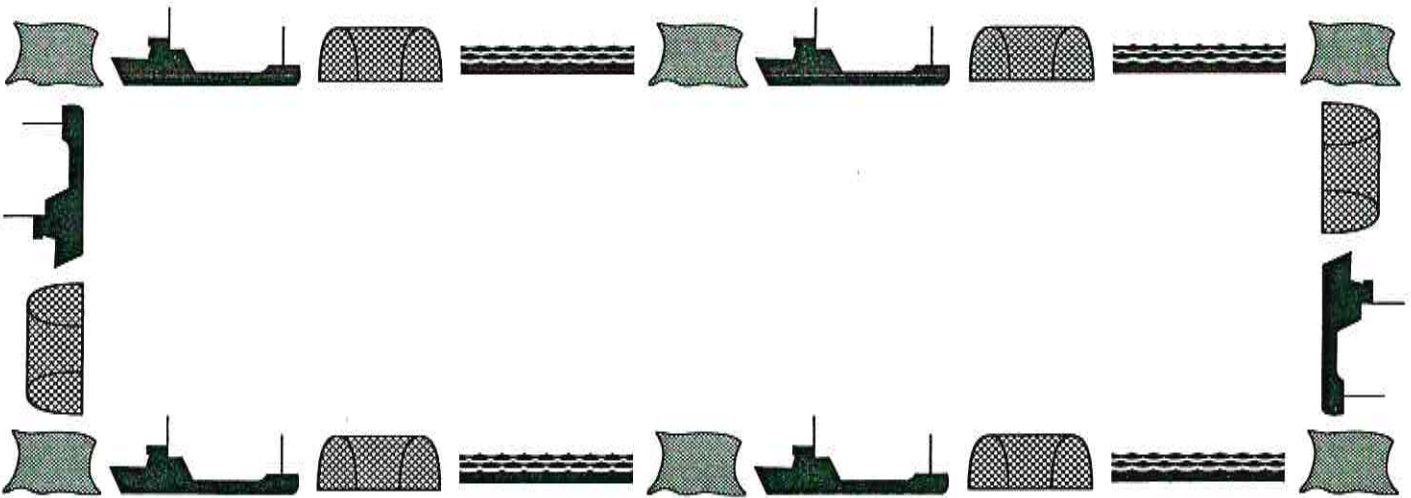

Label the foods you have drawn.

What is your favourite food?

---

Find out which country your favourite food comes from.



# Famous Caymanians



Who are these people?

Their names are in the box below.

Write the correct name under each photograph.

Miss Genevieve Bodden

Captain Keith Tibbetts

Miss Annie Hulda Bodden

Mr Bertie Ebanks

Tell the story of one of the four people shown here.



# Transport in the past and today

Look carefully at these pictures. Write P against transport from the past. Write T against transport we use today.

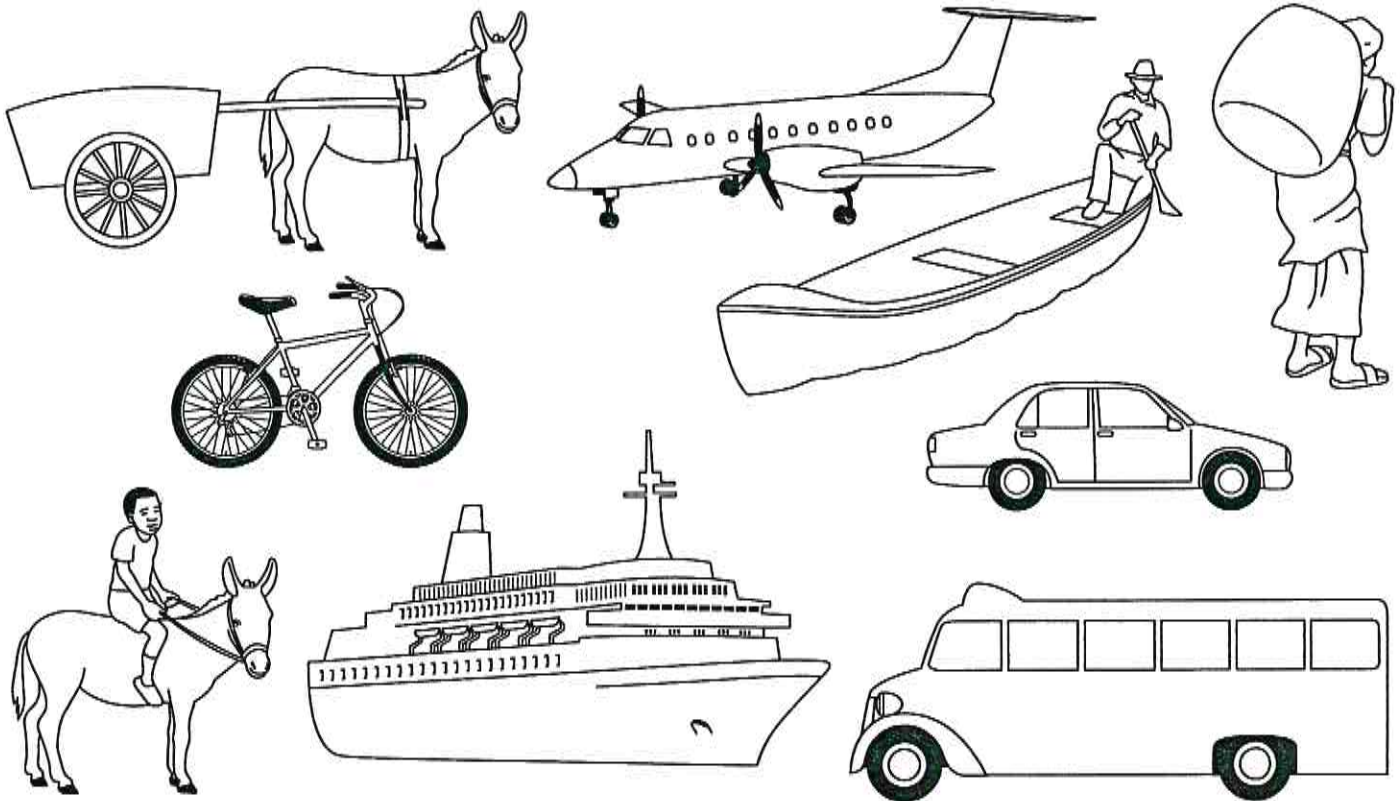

This table shows some transport from the past and today. Add some more examples to it.

Transport	Used in the past	Used today
Aeroplane Donkey	✓	✓

# Special times

Talk about what is happening in each picture.  
Write a sentence for each picture.



---

---



---

---

---

---

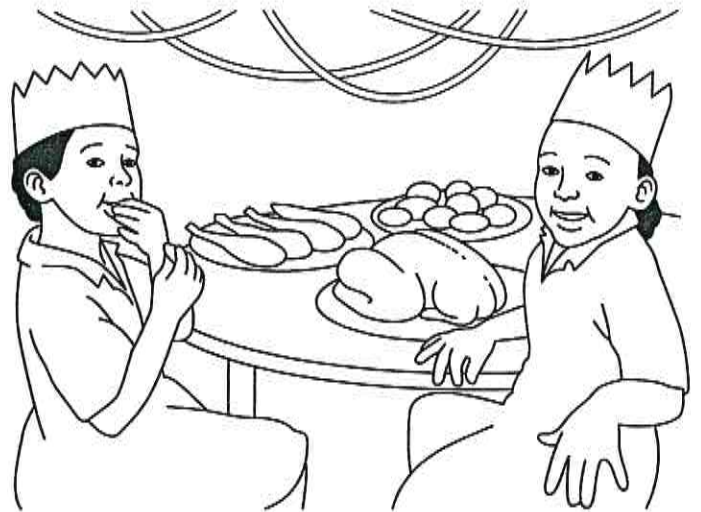

Which is your favourite time?

---

# Our flag and Coat of Arms

This is our flag. Colour it correctly.

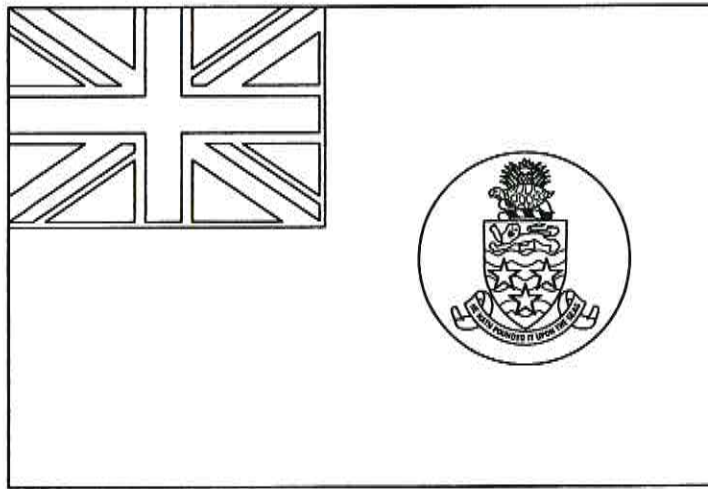

What two things can you see on our flag?

---

---

Colour the Coat of Arms correctly.



Label the Coat of Arms using words from the box below.

pineapple   turtle   rope   lion   stars   the sea   motto

# Our National Symbols

Colour and name each of these symbols.

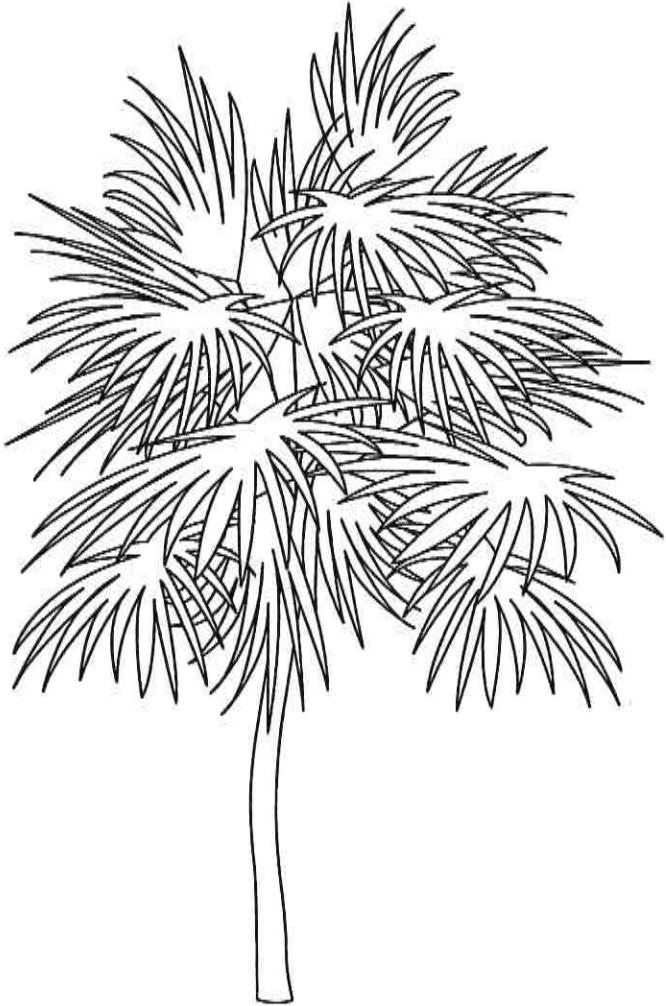

---

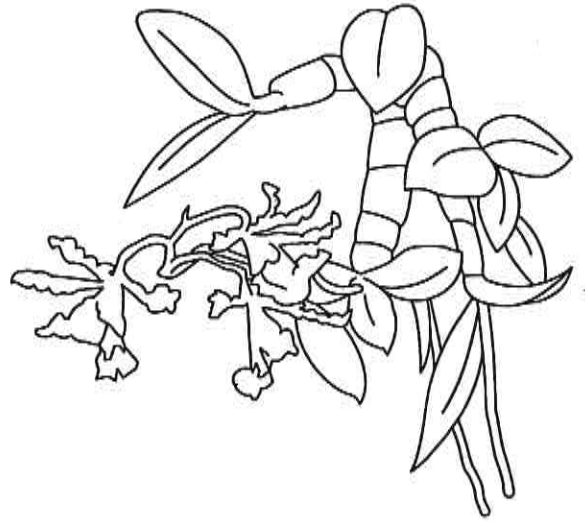

---



---



# Our National Song

This is the chorus of our National Song. Some words are missing. Sing the song and fill in the missing words.

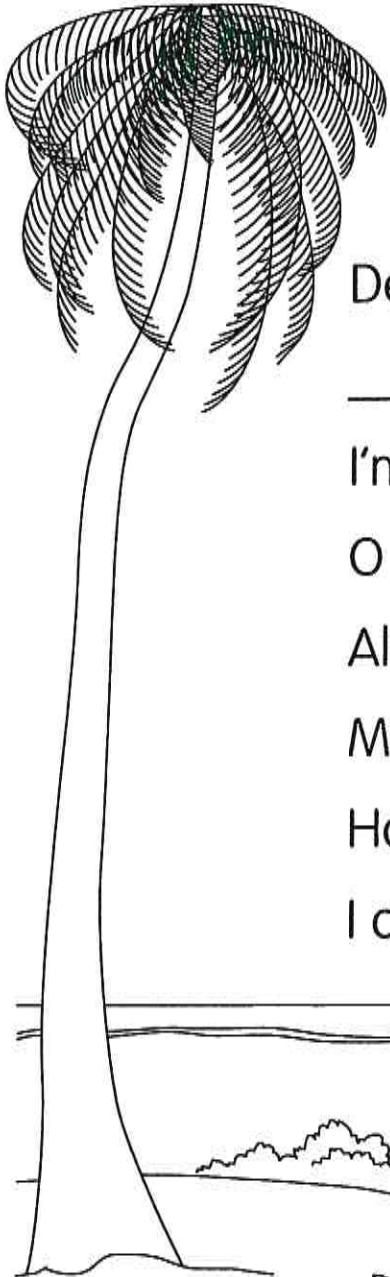

Dear verdant \_\_\_\_\_, set in  
\_\_\_\_\_ Caribbean \_\_\_\_\_,  
I'm coming, \_\_\_\_\_ very soon,  
O beautiful isle, to thee.  
Although I've wandered \_\_\_\_\_,  
My \_\_\_\_\_ enshrines thee yet.  
Homeland, fair \_\_\_\_\_ Isle,  
I cannot \_\_\_\_\_ forget.

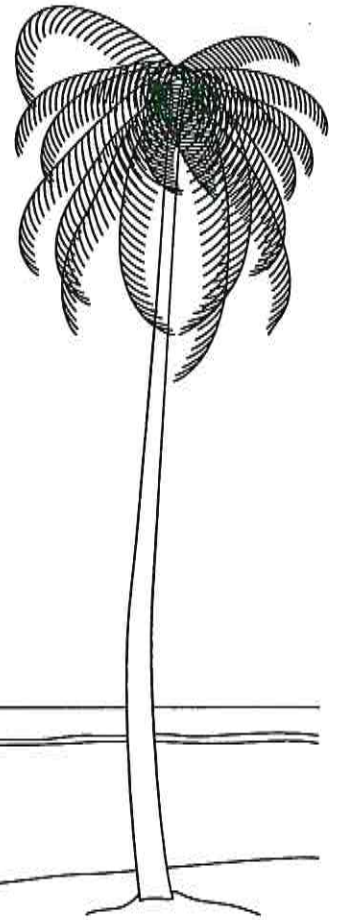

Do you understand what the words of the song mean? Circle any words you are not sure of. Ask your teacher or parent about them.

Cut out these pictures and words.



happy



sad



angry

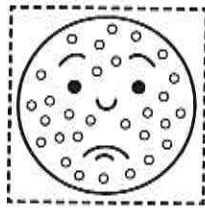

ill



hungry

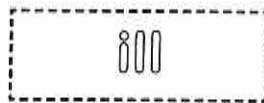
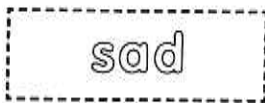

Stick the words and pictures onto page 9.

Cut out the labels. Label the rooms on page 21.

bedroom

bathroom

sitting room

kitchen

Colour and cut out the furniture. Stick it in the correct rooms on page 21.

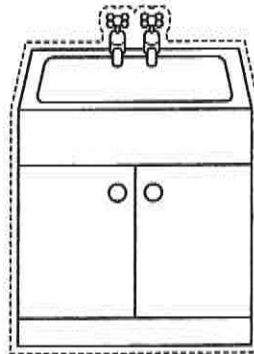
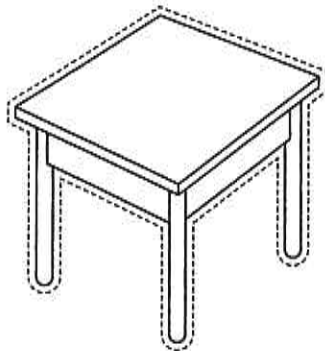
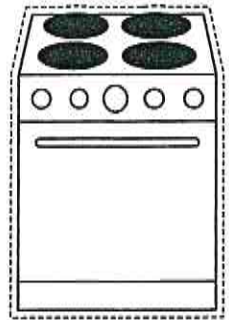
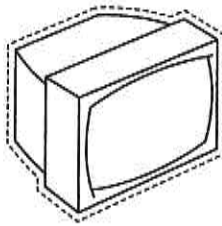
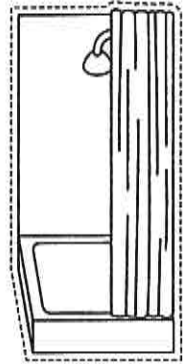
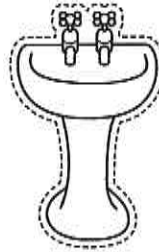
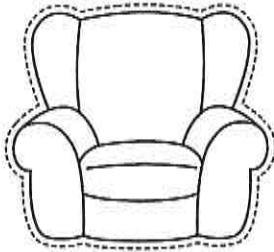
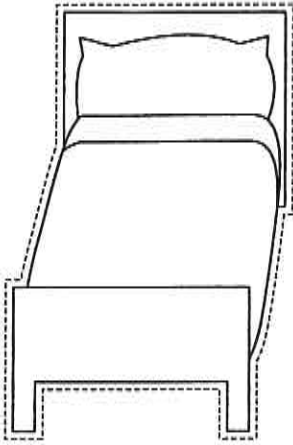



CAYMAN

# CAYMAN

## Primary Social Studies



Cayman Primary Social Studies Workbooks 1-6 have been written to accompany the Cayman Primary Social Studies Textbooks 1-6 and each Workbook closely follows the scheme of work suggested by the Social Studies Curriculum Guide and its Learning Outcomes for the year.

The Workbooks build on the work in the Textbooks and activities in the Teacher's Guides, allowing practise of skills and revision of knowledge. They can be used by teachers in the classroom or to provide homework tasks for the children.

[www.macmillan-caribbean.com](http://www.macmillan-caribbean.com)



MACMILLAN  
CARIBBEAN

ISBN 978-0-333-98804-6



9 0 1 0 1